

**YASKAWA**

# HV600 Catalog

HVAC DRIVES FOR FAN AND PUMP APPLICATIONS

**IT'S PERSONAL**



**Copyright © 2021~2022 YASKAWA AMERICA, INC.**

All rights reserved. No part of this publication may be reproduced, stored in a retrieval system, or transmitted, in any form or by any means, mechanical, electronic, photocopying, recording, or otherwise, without the prior written permission of Yaskawa. No patent liability is assumed with respect to the use of the information contained herein. Moreover, because Yaskawa is constantly striving to improve its high-quality products, the information contained in this manual is subject to change without notice. Every precaution has been taken in the preparation of this manual. Yaskawa assumes no responsibility for errors or omissions. Neither is any liability assumed for damages resulting from the use of the information contained in this publication.

## Table of Contents

Preface .....	4
A Single Drive for All Your Building Automation Needs .....	4
HV600 AC HVAC Fan & Pump Drives .....	5
HV600 Options .....	10
UL Type 1 End Cap Kits .....	10
External Heatsink Kits .....	10
Control Options .....	12
Keypads, Accessories, and Cables .....	13
dV/dT Filters .....	15
Filter Dimensions .....	17
HV600 Dimensions and Data .....	19
Input and Output Reactors .....	22
Input Reactors .....	22
Output Reactors .....	24
Open Reactor Dimensions .....	25
Type 1 (Enclosed) AC Reactor Dimensions .....	27
Narrow Bypass, UL Type 1 (H6BP) .....	30
Catalog Code Configuration (H6BP) .....	31
Package Options (H6BP) .....	31
Model Selection .....	32
Dimensions and Data .....	33
Narrow Bypass, UL Type 12 (H6BN) .....	35
Catalog Code Configuration (H6BN) .....	36
Package Options (H6BN) .....	36
Model Selection .....	37
Dimensions and Data .....	38
Enclosed Bypass, UL Type 1 (H6B1) .....	40
Catalog Code Configuration (H6B1) .....	41
Package Options (H6B1) .....	42
Model Selection .....	42
Dimensions and Data (H6B1) .....	45
Enclosed Bypass, UL Type 12 (H6B2) .....	48
Catalog Code Configuration (H6B2) .....	49
Package Options (H6B2) .....	50
Model Selection .....	50
Dimensions and Data (H6B2) .....	53
Enclosed Bypass, UL Type 3R (H6B3) .....	56
Catalog Code Configuration (H6B3) .....	57
Package Options (H6B3) .....	58
Model Selection .....	59
Dimensions and Data (H6B3) .....	62
Narrow Configured, UL Type 1 (H6CP) .....	65
Catalog Code Configuration (H6CP) .....	66

Package Options (H6CP) . . . . .	66
Model Selection . . . . .	67
Dimensions and Data . . . . .	68
Narrow Configured, UL Type 12 (H6CN) . . . . .	70
Catalog Code Configuration (H6CN) . . . . .	71
Package Options (H6CN) . . . . .	71
Model Selection . . . . .	72
Dimensions and Data . . . . .	73
Enclosed Configured, UL Type 1 (H6C1) . . . . .	75
Catalog Code Configuration (H6C1) . . . . .	76
Package Options (H6C1) . . . . .	77
Model Selection . . . . .	77
Dimensions and Data (H6C1) . . . . .	80
Enclosed Configured, UL Type 12 (H6C2) . . . . .	83
Catalog Code Configuration (H6C2) . . . . .	84
Package Options (H6C2) . . . . .	85
Model Selection . . . . .	85
Dimensions and Data (H6C2) . . . . .	88
Enclosed Configured, UL Type 3R (H6C3) . . . . .	91
Catalog Code Configuration (H6C3) . . . . .	92
Package Options (H6C3) . . . . .	93
Model Selection . . . . .	94
Dimensions and Data (H6C3) . . . . .	97
Redundant Drive Packages (H6R) . . . . .	100
Catalog Code Configuration (H6R) . . . . .	101
Package Options (H6R) . . . . .	102
Model Selection . . . . .	102
Dimensions and Data (H6R) . . . . .	104
Z1000U Matrix Drive . . . . .	105
Catalog Code Configuration (Z1000U) . . . . .	106
Z1000U Matrix Options . . . . .	108
UL Type 1 End Cap Kits . . . . .	108
24 VDC Control Power Unit . . . . .	109
UL Type External Heatsink Kits . . . . .	109
Control and Communication Options . . . . .	111
Z1000U Matrix Drive Dimensions and Data . . . . .	114
Z1000U Matrix Bypass Drive UL Type 1 . . . . .	115
Catalog Code Configuration (Z1D1) . . . . .	116
Package Options (Z1D1) . . . . .	117
Model and Power Option Section (Z1D1) . . . . .	118
Dimensions and Data (Z1D1) . . . . .	119
Z1000U Matrix Bypass Drive UL Type 3R . . . . .	120
Catalog Code Configuration (Z1D3) . . . . .	121
Package Options (Z1D3) . . . . .	122
Model and Power Options (Z1D3) . . . . .	123

Dimensions and Data (Z1D3).....	124
Z1000U Matrix Configured Drive UL Type 1 .....	125
Catalog Code Configuration (Z1E1).....	126
Package Options (Z1E1) .....	127
Model and Power Option Selection .....	127
Dimensions and Data (Z1E1) .....	128
Z1000U Matrix Configured Drive UL Type 3R.....	130
Catalog Code Configuration (Z1E3).....	131
Package Options (Z1E3) .....	132
Model and Power Option Selection (Z1E3) .....	133
Dimensions and Data (Z1E3) .....	134
Terms and Conditions .....	135

## Preface

### A Single Drive for All Your Building Automation Needs

The HV600 variable-frequency drive is designed for building automation applications such as fans, pumps, and cooling towers through 250 HP. The HV600 features HVAC-specific application presets, a high-contrast, easy-to-read LCD keypad with tactile buttons that provides Hand-Off-Auto interface, a high-visibility Status Ring, and a real-time clock. These features make the HV600 perfect for most building automation applications that require reliable motor control.

Yaskawa America, Inc. has been building packages for the HVAC industry since 1988. Over that time, we have worked rigorously to evolve our products and exceed industry standards, while ensuring an exceptional customer experience.

Our latest offering for the HVAC industry, the HV600 family of drives, pushes past the standard requirements to establish a new benchmark for expectations within the industry.

Yaskawa embraces the challenge of supplying an essential product into a growing and changing market. Customers of all types are demanding more flexibility, more control, more power, less downtime, and more packaging options. The HV600 family of drives is able to address and exceed all of these expectations.

This document may describe trademarked equipment, which is the property of other companies. These trademarks are the property of the registered owner companies and may include the following:

- Android™ is a trademark of Google LLC
- APOGEE® FLN is a registered trademark of Siemens Building Technologies, Inc.
- BACnet™ is a trademark of the American Society of Heating, Refrigerating, and Air-Conditioning Engineers (ASHRAE).
- EtherNet/IP® is a registered trademark of Open DeviceNet Vendor Association, Inc. (ODVA)
- App Store® are registered trademarks of Apple Inc.
- LonWorks® a registered trademark of the Echelon Corporation
- Metasys® N2 is a trademark of Johnson Controls, Inc.
- Modbus® trademark of Schneider Automation, Inc.
- USB and ON-THE GO™ logos are trademarks of USB Implementers Forum, Inc.
- Bluetooth® word mark and logos are registered trademarks owned by Bluetooth SIG, Inc.
- Google Play and the Google Play logo are trademarks of Google LLC.

Other documents and manuals are available to support special use or installation of products. These documents may be provided with the product or upon request. Contact Yaskawa America, Inc. or visit [www.yaskawa.com](http://www.yaskawa.com).

Unless otherwise noted, throughout this document, the term "Type", when related to enclosure solutions, refers not only to NEMA Type, but also represents UL Listing for the specific Type(s).



# HV600 AC HVAC Fan & Pump Drives



The HV600 variable-frequency drive is engineered for use in HVAC building automation applications requiring reliable motor control.

The HV600 features your choice of IP20/UL Type 1, IP55/UL Type 12, IP55/UL Type 12 with switch, or IP20/Protected Chassis protection. Every HV600 comes with HVAC application-specific software presets, a Hand-Off-Auto LCD keypad, a high-visibility Status Ring for quick visual indication of drive status, and a real-time clock for system accuracy. Popular building automation communication protocols BACnet, Siemens APOGEE, Johnson Controls Metasys, and MEMOBUS/Modbus are embedded in the drive. Interface cards for LonWorks and EtherNet/IP communications are offered separately.

Program the drive prior to installation and upgrade firmware without the need for three-phase main power. Use the free Yaskawa Drive Cloud with the DriveWizard® Mobile Application for parameter backups and wired programming with an Android smart device.

## Performance Features

- VT Ratings:
  - 3 to 100 HP, 200 to 240 VAC
  - 3 to 250 HP, 480 VAC
- 5 % split choke built-in for both positive/negative DC bus leg as standard
- EMC filter built-in: complies with IEC 61800-3 restricted distribution for first environment
- Overload capacity: 110% for 60 seconds, 140% for 2 seconds, 175% instantaneous
- DC Injection braking: at start or stop, adjustable, current limited (anti-windmilling)
- Motor preheat function
- Adjustable Accel/Decel: 0.1 to 6000 seconds
- Controlled speed range: 40:1 (V/f)
- Maximum output frequency: 400 Hz
- Safe Torque Off: SIL3, PLE
- 24 VDC power output to power sensors and other devices (150 mA)
- 24 VDC external power input to maintain network communications and allow for keypad programming and monitoring during a three-phase power loss
- Temperature controlled fans
- Critical frequency rejection capability: 3 selectable, adjustable bands
- Torque limiting: 30 to 180%
- Power loss ride-through: 2 seconds

- Auto restart after power loss or resettable fault, selectable, programmable
- Serial communications loss detection
- Up/down floating point control capability
- Stationary motor auto-tuning
- 140% starting torque capability, available from 3 Hz to 60 Hz
- Remote speed reference (speed command) signal:
  - 0 to 10 VDC (20 K Ohm)
  - 0 to 20 mA DC (250 Ohm)
  - 4 to 20 mA DC (250 Ohm)
- 7 programmable multi-function input terminals (24 VDC) providing 60+ programmable features, including:
  - Customer safeties
  - BAS / damper interlock
  - Emergency Override
  - Preset speed
  - PID control enable / disable
- 3 programmable multi-function output relays (Form A rated 2 amps @ 250 VAC & 30 VDC), providing 50+ functions, including:
  - Damper control
  - Hand/Auto status
  - Contactor control for external bypass
  - Overtorque/Undertorque detection
- Voltmeter, ammeter, kilowatt meter, elapsed run time meter, and heat sink temperature monitoring functions
- Two internal PID closed-loop control with selectable engineering units

- Independent PID control for use with external device

## Service Conditions

- Input voltage:
  - 200 to 240 VAC, 380 to 480 VAC, -15/+10%
- Input frequency: 50/60 Hz ±5%
- Ambient operating temperature:
  - 40°C for IP20/UL Type 1 & IP55/UL Type 12
  - 50°C for IP20/UL Protected Chassis
  - 50 °C maximum with derate for IP55/UL Type 12
  - 60 °C maximum with derate for IP20/UL Type 1 and IP20/UL Protected Chassis
- Ambient storage temperature: -20 °C to 70 °C (-4 °F to 158 °F)
- Humidity: 0% to 95% non-condensing
- Altitude: to 1000 meters; 4000 meters with derate
- Service factor: 1.0
- Vibration: 9.81 m/s<sup>2</sup> (1 G) maximum at 10 to 20 Hz, 2.0 m/s<sup>2</sup> (0.2 G) at 20 Hz to 55 Hz
- Plenum mounting capable; IP20/UL Type 1 & IP55/UL Type 12
- RoHS 2 compliant
- Conformal coating (IEC 60721-3-3, IP20/UL Type 1: 3C2, 3S2; IP55/UL Type 12: 3C2, 3S3)

## Ease of Use Features

- LED Status Ring for clear drive operational status
- Programming and firmware upgrade without three-phase main power
- QR code for Yaskawa Drive Cloud registration
- Short circuit current rating (SCCR) on name-plate
- In box mounting templates and startup instructions

## Flexibility Features

- Cloud service (Yaskawa Drive Cloud) for product registration and parameter storage
- 24 VDC customer supplied input terminal for power loss ride-through
- Integrated 24 VDC control power for customer use (150 mA, max)
- Simplified Integrated Modbus RTU control (D+/D-)
- USB Mini B PC interface port

## Key Programming Features

- Expert access level for power users
- Digital output off-delay time settings
- Control additional digital inputs using Modbus registers and with other network protocols
- Digital input on and off delay time settings
- Digital output logic operation – output activates based on results of two digital output functions
- Built-in BACnet protocol (BTL certified)

- BACnet Health Monitor feature for setup and troubleshooting
- Maximum BACnet frame limit – limits number of messages sent while holding BACnet token
- Customizable fault reset – enable/disable fault reset for low feedback, high feedback, feedback loss, speed search retry, setpoint not met, loss of prime
- DC bus stabilization for quicker deceleration times
- Custom monitors - home screen, up to 12 custom monitors
- Customer screens – bar graphs, trend, and analog gauge
- Date/time stamp for all drive faults
- Keypad backlight adjustment
- Select motor power unit display (HP or kW)
- Auto parameter back up into keypad
- Store up to four additional parameter sets in keypad
- Data logging – record status of up to 10 monitors with adjustable sample time
- Integrated PLC logic control (DriveWorksEZ)
- HAND mode PID setpoint selection
- AUTO key status memory during power loss
- Improvements to emergency override – BAS interlock mode, min/max speed setting, 16 preset speeds, and more
- Fully customizable auxiliary PID control
- Output current limit selection
- Single phase fold back

## Standard PID Control Features

- Integrator ramp limit
- Select PID feedback to be a drive monitor
- PID Proportional Trim
- Select PID differential feedback to be a drive monitor
- 3 PID system unit customer characters
- 4-20 mA wire break detection

## Standards

- UL 508C (Power Conversion)
- CSA 22.2 No. 274-2017 (Adjustable Speed Drives)
- UL 1995 (Plenum)
- CE mark 2014/35/EU LVD
- CE mark 2006/42/EC MD
- CE mark 2014/30/EU EMC
- EN 61800-5-1 (LVD)
- EN 61800-3
- IEC 60529
- IEEE C62.41
- UL, cUL listed; CE marked
- Seismic: HCAI (OSHPD), CBC, IBC, ICC-ES AC156

## Options

- LonWorks Interface
- EtherNet/IP
- Modbus TCP/IP

## Catalog Code Designation

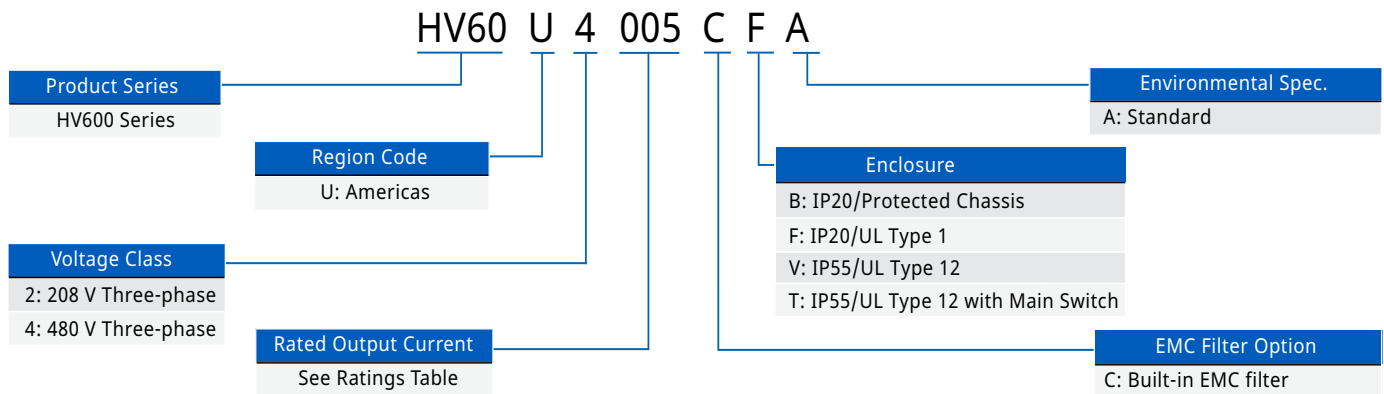



Table 1: 3 to 100 HP, 208 V, 3-phase input, IP20/UL Type 1 or IP20/Protected Chassis

Rated Input Voltage	Nominal HP <sup>1</sup>	Rated Output Current (Amps)	Drive Catalog Code	Standard Protection
208 V 3-Phase	3	10.6	HV60U2011CFA	IP20/UL Type 1
	5	16.7	HV60U2017CFA	
	7.5	24.2	HV60U2024CFA	
	10	30.8	HV60U2031CFA	
	15	46.2	HV60U2046CFA	
	20	59.4	HV60U2059CFA	
	25	74.8	HV60U2075CFA	
	30	88	HV60U2088CFA	
	40	114	HV60U2114CFA	
	50	143	HV60U2143CFA	
	60	169	HV60U2169CFA	
	75	211	HV60U2211CBA	IP20/Protected Chassis
100	273	HV60U2273CBA		

1. Horsepower rating is based on standard NEMA B, 4-pole motor design as represented in NEC table 430.150 Full-Load Current, Three-Phase Alternating Current Motors at 208 volts.

Table 2: 3 to 250 HP, 480 V, 3-phase input, IP20/UL Type 1 or IP20/Protected Chassis

Rated Input Voltage	Nominal HP <sup>1</sup>	Rated Output Current (Amps)	Drive Catalog Code	Standard Protection
480 V 3-Phase	3	4.8	HV60U4005CFA	IP20/UL Type 1
	5	7.6	HV60U4008CFA	
	7.5	11	HV60U4011CFA	
	10	14	HV60U4014CFA	
	15	21	HV60U4021CFA	
	20	27	HV60U4027CFA	
	25	34	HV60U4034CFA	
	30	40	HV60U4040CFA	
	40	52	HV60U4052CFA	
	50	65	HV60U4065CFA	
	60	77	HV60U4077CFA	
	75	96	HV60U4096CFA	
	100	124	HV60U4124CFA	
	125	156	HV60U4156CFA	
	150	180	HV60U4180CBA	
	200	240	HV60U4240CBA	
	250	302	HV60U4302CBA	

1. Horsepower rating is based on standard NEMA B, 4-pole motor design as represented in NEC table 430.150 Full-Load Current, Three-Phase Alternating Current Motors at 480 volts.

Table 3: 3 to 40 HP, 208 V, 3-phase input, IP55/UL Type 12

Rated Input Voltage	Nominal HP <sup>1</sup>	Rated Output Current (Amps)	Drive Catalog Code	Standard Protection
208 V 3-Phase	3	10.6	HV60U2011CVA	IP55/UL Type 12
	5	16.7	HV60U2017CVA	
	7.5	24.2	HV60U2024CVA	
	10	30.8	HV60U2031CVA	
	15	46.2	HV60U2046CVA	
	20	59.4	HV60U2059CVA	
	25	74.8	HV60U2075CVA	
	30	88	HV60U2088CVA	
40	114	HV60U2114CVA		

1. Horsepower rating is based on standard NEMA B, 4-pole motor design as represented in NEC table 430.150 Full-Load Current, Three-Phase Alternating Current Motors at 208 volts.

Table 4: 3 to 100 HP, 480 V, 3-phase input, IP55/UL Type 12

Rated Input Voltage	Nominal HP <sup>1</sup>	Rated Output Current (Amps)	Drive Catalog Code	Standard Protection
480 V 3-Phase	3	4.8	HV60U4005CVA	IP55/UL Type 12
	5	7.6	HV60U4008CVA	
	7.5	11	HV60U4011CVA	
	10	14	HV60U4014CVA	
	15	21	HV60U4021CVA	
	20	27	HV60U4027CVA	
	25	34	HV60U4034CVA	
	30	40	HV60U4040CVA	
	40	52	HV60U4052CVA	
	50	65	HV60U4065CVA	
	60	77	HV60U4077CVA	
	75	96	HV60U4096CVA	
100	124	HV60U4124CVA		

1. Horsepower rating is based on standard NEMA B, 4-pole motor design as represented in NEC table 430.150 Full-Load Current, Three-Phase Alternating Current Motors at 480 volts.

Table 5: 3 to 40 HP, 208 V, 3-Phase Input, IP55/UL Type 12 with Main Switch

Rated Input Voltage	Nominal HP	Rated Output Current (Amps)	Drive Catalog Code	Standard Protection
208 V 3-Phase	3	11	HV60U2011CTA	IP55/UL Type 12
	5	17	HV60U2017CTA	
	7.5	24	HV60U2024CTA	
	10	31	HV60U2031CTA	
	15	46	HV60U2046CTA	
	20	59	HV60U2059CTA	
	25	75	HV60U2075CTA	
	30	88	HV60U2088CTA	
40	114	HV60U2114CTA		

Table 6: 3 to 75HP, 480 V, 3-Phase, IP55/UL Type 12 with Main Switch

Rated Input Voltage	Nominal HP	Rated Output Current (Amps)	Drive Catalog Code	Standard Protection
480 V 3-Phase	3	5	HV60U4005CTA	IP55/UL Type 12
	5	8	HV60U4008CTA	
	7.5	11	HV60U4011CTA	
	10	14	HV60U4014CTA	
	15	21	HV60U4021CTA	
	20	27	HV60U4027CTA	
	25	34	HV60U4034CTA	
	30	40	HV60U4040CTA	
	40	52	HV60U4052CTA	
	50	65	HV60U4065CTA	
	60	77	HV60U4077CTA	
	75	96	HV60U4096CTA	

## HV600 Options

### UL Type 1 End Cap Kits

This option consists of a top and bottom cover to convert a protected IP20/Protected Chassis drive to a IP20/UL Type 1 enclosed unit. This option does not provide additional space for mounting auxiliary components, for example circuit breakers, input fuses, or reactors.

Rated Input Voltage	Drive Model Number HV60U. . . .	Part Number
208 to 240 V 3-Phase	2211CBA	900-192-121-009
	2273CBA	
480 V 3-Phase	4180CBA	900-192-121-009
	4240CBA	
	4302CBA	900-192-121-010

### External Heatsink Kits

External heatsink kits allow drives to be mounted with the drive's heat sink external to the enclosure. Option kit for customer mounting. Available in either UL Type 1 or UL Type 12.

Table 7: UL Type 1 External Heatsink Kits for 200 to 240 V Models

Rated Input Voltage	Drive Model Number HV60U. . . .	Part Number
200 to 240 V 3-Phase	2011	ZPSA-600-EH1-FR1
	2017	
	2024	ZPSA-600-EH1-FR2
	2031	
	2046	ZPSA-600-EH1-FR3
	2059	
	2075	ZPSA-600-EH1-FR4
	2088	
	2114	Contact Factory
	2143	
	2169	
	2211	
	2273	

Table 8: UL Type 1 External Heatsink Kits for 480 V Models

Rated Input Voltage	Drive Model Number HV60U. . . .	Part Number
480 V 3-Phase	4005	ZPSA-600-EH1-FR1
	4008	
	4011	
	4014	
	4021	ZPSA-600-EH1-FR2
	4027	
	4034	
	4040	ZPSA-600-EH1-FR3
	4052	
	4065	
	4077	ZPSA-600-EH1-FR4
	4096	
	4124	
	4156	Contact Factory
	4180	
	4240	
4302		

Table 9: UL Type 12 External Heatsink Kits for 200 to 240 V Models

Rated Input Voltage	Drive Model Number HV60U. . . .	Part Number
200 to 240 V 3-Phase	2011	ZPSD-600-EH12-FR1
	2017	ZPSD-600-EH12-FR2
	2024	
	2031	
	2046	ZPSD-600-EH12-FR3
	2059	ZPSD-600-EH12-FR4
	2075	
	2088	
	2114	ZPSD-600-EH12-FR6
	2143	
	2169	
	2211	ZPSD-600-EH12-FR9
	2273	

Table 10: UL Type 12 External Heatsink Kits for 380 to 480 V Models

Rated Input Voltage	Drive Model Number HV60U... .	Part Number
380 to 480 V 3-Phase	4005	ZPSD-600-EH12-FR1
	4008	
	4011	
	4014	
	4021	ZPSD-600-EH12-FR2
	4027	
	4034	
	4040	ZPSD-600-EH12-FR3
	4052	
	4065	ZPSD-600-EH12-FR4
	4077	
	4096	
	4124	ZPSD-600-EH12-FR6
	4156	
	4180	ZPSD-600-EH12-FR9
	4240	ZPSD-600-EH12-FR10
4302		

## Control Options



Control Options - These cards and devices add control functionality to the standard drive. Items are shipped loose, unmounted.

### Additional Information

#### Network Communications

Table 11: Network Communications

Part Number	Description
SI-EN3	EtherNet/IP
SI-EN3D	EtherNet/IP dual port
JOHB-SMP3-MA	BACnet/IP dual port (Multi-Protocol Ethernet Card) - Protocol set via DIP switches.
SI-EM3	Modbus TCP/IP
SI-EM3D	Modbus TCP/IP dual port
SI-W3	LonWorks

## Keypads, Accessories, and Cables

Additional Information	
Keypads and Cables	

Table 12: Keypads and DriveWizard Mobile

Part Number	Description
JVOP-KPLCB04AEB	LCD Keypad
JVOP-KPLCD04ABB	Bluetooth® LCD Keypad



LCD Keypad



Bluetooth® LCD Keypad

The Bluetooth® Enabled Keypad provides a wireless connection to your smartphone or tablet. Start-up, adjust, and monitor Yaskawa's new AC drives with your smartphone or tablet. Use DriveWizard® Mobile to backup, store, and retrieve your drive settings locally or to your personal Yaskawa Drive Cloud™ account. DriveWizard Mobile is the mobile app version of Yaskawa's DriveWizard® PC Tools.

DriveWizard Mobile <https://www.yaskawa.com/dwm>



Table 13: Remote Mount Adapters

Part Number	Description
900-192-933-001	Type 1 Keypad Panel Mount Kit A (brackets have tapped holes for use with screws)
900-192-933-002	Type 1 Keypad Panel Mount Kit B (brackets have untapped holes for use with panel studs)
900-239-230-001	Type 12/3R Keypad Panel Mount Kit (with embedded studs)
UUX001955	Type 4/4X Keypad Panel Mount Kit (with embedded studs)

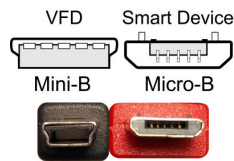

Table 14: Cables

Part Number	Description
UWR0051	Keypad Remote Cable - 1 Meter
UWR0052	Keypad Remote Cable - 3 Meter
UWR01258	USB Cable for PC to Drive Communication - 3 Meter

Table 15: Android Mobile Device Interface Cables  
(for connecting Android device to USB port on drive)

Part Number	Description
UWR01516-B	USB Cable, USB Mini-B to USB Micro-B. On-The-Go (OTG) compatible, 2-meter length.
UWR01516-C	USB Mini-B to USB Type-C. On-The-Go (OTG) compatible, 2-meter length.



P# UWR01516-B - USB Mini-B to USB Micro-B

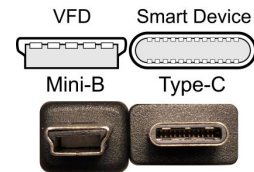

P# UWR01516-C - USB Mini-B to USB Type-C



## dV/dT Filters

dV/dt filters help prevent voltage spikes from variable frequency drives (VFD) from exceeding 1,000 V.

- Limits voltage spikes to below 1,000 V for applications with lead lengths up to 1,000 ft
- Reduces motor heating, noise and vibration.
- Prevents motor failure with protection against motor insulation breakdown.
- Reduces Common Mode by a minimum of 30%.
- Improves system productivity by increasing motor bearing life

Table 16: dV/dT Filter in UL Type 1 Enclosure

Part Number	NEC Motor HP			Current Rating
	208V	480V	600V	
UFI000702	-	0.75	1	2
UFI000703	0.5	1 - 1.5	2	3
UFI000704	0.75	2	3	4
UFI000705	1	3	-	6
UFI000706	1.5 - 2	5	5	8
UFI000707	3	7.5	10	12
UFI000708	-	10	-	16
UFI000709	5	10	15	18
UFI000710	-	15	-	21
UFI000711	7.5	15	20	25
UFI000712	-	20	25	27
UFI000713	10	25	30	35
UFI000714	-	30	40	45
UFI000715	15	40	50	55
UFI000716	25	50 - 60	75	80
UFI000717	30	75	100	110
UFI000718	40	100	125	130
UFI000719	50	125	150	160
UFI000720	60	150	200	200
UFI000721	75	200	250	250
UFI000722	100	250	300	305
UFI000723	125	300	350	362
UFI000724	150	350	450	420
UFI000725	-	400	500	480
UFI000726	200	500	600	600
UFI000727	-	600	700	750

Table 17: dV/dT Filter in UL Type 3R Enclosure

Part Number	NEC Motor HP			Current Rating
	480V	600V	208V	
UFI000728	0.75	1	-	2
UFI000729	1 - 1.5	2	0.5	3
UFI000730	2	3	0.75	4
UFI000731	3	-	1	6
UFI000732	5	5	1.5 - 2	8
UFI000733	7.5	10	3	12
UFI000734	10	-	-	16
UFI000735	10	15	5	18
UFI000736	15	-	-	21
UFI000737	15	20	7.5	25
UFI000738	20	25	-	27
UFI000739	25	30	10	35
UFI000740	30	40	-	45
UFI000741	40	50	15	55
UFI000742	50 - 60	75	25	80
UFI000743	75	100	30	110
UFI000744	100	125	40	130
UFI000745	125	150	50	160
UFI000746	150	200	60	200
UFI000747	200	250	75	250
UFI000748	250	300	100	305
UFI000749	300	350	125	362
UFI000750	350	450	150	420
UFI000751	400	500	-	480
UFI000752	500	600	200	600
UFI000753	600	700	-	750

## Filter Dimensions

Figure 1: Models 702-721

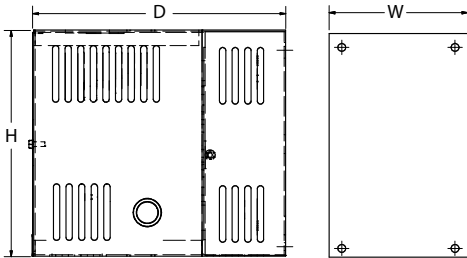

Figure 2: Models 722-727

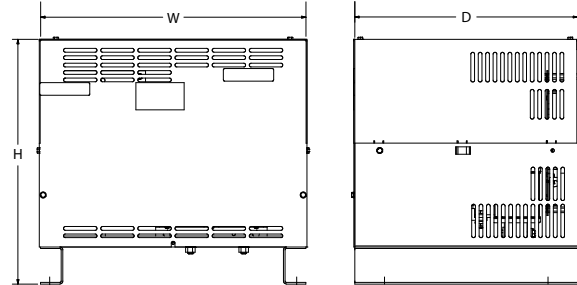

Table 18: UL Type 1 Filter Dimensions

Model Number	Rated Current (A)	Figure	Height	Width	Depth	Weight (lbs)
UFI000702	2	1	9	5.5	10	11
UFI000703	3					
UFI000704	4					
UFI000705	6					
UFI000706	8					
UFI000707	12					15
UFI000708	16					
UFI000709	18					
UFI000710	21					
UFI000711	25					
UFI000712	27	2	16.5	18	30	23
UFI000713	35					
UFI000714	45					
UFI000715	55					
UFI000716	80					
UFI000717	110					68
UFI000718	130					
UFI000719	160					
UFI000720	200					
UFI000721	250					
UFI000722	305	2	16.5	18	30	117
UFI000723	362					
UFI000724	420					
UFI000725	480					
UFI000726	600					
UFI000727	750					

Figure 3: Models 728-753

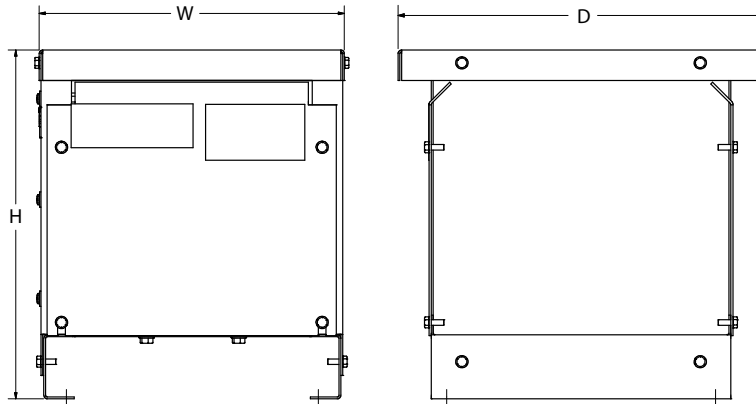

Table 19: UL Type 3R Filter Dimensions

Model Number	Rated Current (A)	Figure	Height	Width	Depth	Weight (lbs)
UFI000728	2	3	11.5	10	12	25
UFI000729	3					
UFI000730	4					
UFI000731	6					
UFI000732	8					
UFI000733	12					
UFI000734	16					
UFI000735	18					
UFI000736	21					29
UFI000737	25					
UFI000738	27					
UFI000739	35					
UFI000740	45					
UFI000741	55		19.2	15.6	19.5	56
UFI000742	80					62
UFI000743	110					74
UFI000744	130					89
UFI000745	160					99
UFI000746	200					
UFI000747	250		22.2	20.6	28.5	109
UFI000748	305	156				
UFI000749	362	161				
UFI000750	420	297				
UFI000751	480	36	28.2	36.7	307	
UFI000752	600					
UFI000753	750					

# HV600 Dimensions and Data

Table 20: 208 V IP20/UL Type 1

Rated Input Voltage	Drive Catalog Code	Nominal HP	Physical Dimensions (in)			Weight (lb)	Drawing Number	Heat Loss (Watts)		
			H	W	D			Heatsink	Internal	Total
208 V 3-Phase	HV60U2011CFA	3	14.1	4.9	8.6	14.3	DD.HV60.FR1.T1	86	50	136
	HV60U2017CFA	5				14.3		140	61	201
	HV60U2024CFA	7.5	17.6		9.2	18.7	DD.HV60.FR2.T1	184	82	267
	HV60U2031CFA	10				19.8		244	96	340
	HV60U2046CFA	15	20.1	7.9	9.3	33.1	DD.HV60.FR3.T1	314	123	437
	HV60U2059CFA	20				35.3		418	155	573
	HV60U2075CFA	25	21.3	10.0	10.4	55.1	DD.HV60.FR4.T1	538	184	722
	HV60U2088CFA	30				55.1		615	210	825
	HV60U2114CFA	40				61.7		780	256	1036
	HV60U2143CFA	50	30.5	12.2	15.7	163.2	DD.HV60.FR6.T1	937	262	1198
HV60U2169CFA	60	167.6				1132		297	1429	

Table 21: 480 V IP20/UL Type 1

Rated Input Voltage	Drive Catalog Code	Nominal HP	Physical Dimensions (in)			Weight (lb)	Drawing Number	Heat Loss (Watts)		
			H	W	D			Heatsink	Internal	Total
480 V 3-Phase	HV60U4005CFA	3	14.1	4.9	8.6	15.4	DD.HV60.FR1.T1	39	39	79
	HV60U4008CFA	5				16.5		63	49	111
	HV60U4011CFA	7.5				15.4		142	61	203
	HV60U4014CFA	10				15.4		196	71	268
	HV60U4021CFA	15	17.6	9.2	19.8	DD.HV60.FR2.T1	212	96	308	
	HV60U4027CFA	20			22.1		285	118	404	
	HV60U4034CFA	25			24.3		327	135	462	
	HV60U4040CFA	30	20.1	7.8	9.3	35.3	DD.HV60.FR3.T1	373	152	525
	HV60U4052CFA	40				39.7		470	185	655
	HV60U4065CFA	50				44.1		600	232	832
	HV60U4077CFA	60	21.3	10.0	10.4	61.7	DD.HV60.FR4.T1	819	281	1100
	HV60U4096CFA	75				66.2		973	332	1305
	HV60U4124CFA	100				72.8		1294	434	1728
	HV60U4156CFA	125				30.5		12.3	15.8	172.0

Table 22: 208 V IP55/UL Type 12

Rated Input Voltage	Drive Catalog Code	Nominal HP	Physical Dimensions (in)			Weight (lb)	Drawing Number	Heat Loss (Watts)		
			H	W	D			Heatsink	Internal	Total
208 V 3-Phase	HV60U2011CVA	3	14.1	4.9	9.0	14.3	DD.HV60.FR1.T1	86	50	136
	HV60U2017CVA	5				14.3		140	61	201
	HV60U2024CVA	7.5	17.6		9.6	18.7	DD.HV60.FR2.T1	184	82	267
	HV60U2031CVA	10				19.8		244	96	340
	HV60U2046CVA	15	20.1	7.9	9.7	33.1	DD.HV60.FR3.T1	314	123	437
	HV60U2059CVA	20				35.3		418	155	573
	HV60U2075CVA	25	21.3	10.0	10.8	55.1	DD.HV60.FR4.T1	538	184	722
	HV60U2088CVA	30				55.1		615	210	825
	HV60U2114CVA	40				61.7		780	256	1,036

Table 23: 208 V IP55/UL Type 12 with Switch

Rated Input Voltage	Drive Catalog Code	Nominal HP	Physical Dimensions (in)			Weight (lb)	Drawing Number	Heat Loss (Watts)		
			H	W	D			Heatsink	Internal	Total
208 V 3-Phase	HV60U2011CTA	3	20.4	4.9	10.0	20.9	DD.HV60.FR1.T12.SW	86	50	136
	HV60U2017CTA	5				20.9		140	61	201
	HV60U2024CTA	7.5	24.5		10.5	26.5	DD.HV60.FR2.T12.SW	184	82	267
	HV60U2031CTA	10				28.7		244	96	340
	HV60U2046CTA	15	31.0	7.9	10.9	48.5	DD.HV60.FR3.T12.SW	314	123	437
	HV60U2059CTA	20				50.7		418	155	573
	HV60U2075CTA	25	39.0	11.4	12.0	90.4	DD.HV60.FR4.T12.SW	538	184	722
	HV60U2088CTA	30				90.4		615	210	825
	HV60U2114CTA	40				97.0		780	256	1,036

Table 24: 480 V IP55/UL Type 12

Rated Input Voltage	Drive Catalog Code	Nominal HP	Physical Dimensions (in)			Weight (lb)	Drawing Number	Heat Loss (Watts)		
			H	W	D			Heatsink	Internal	Total
480 V 3-Phase	HV60U4005CVA	3	14.1	4.9	9.0	15.4	DD.HV60.FR1.T12	39	39	79
	HV60U4008CVA	5				16.5		63	49	111
	HV60U4011CVA	7.5			15.4	142		61	203	
	HV60U4014CVA	10			15.4	196		71	268	
	HV60U4021CVA	15	17.6		9.6	19.8	DD.HV60.FR2.T12	212	96	308
	HV60U4027CVA	20				22.0		285	118	404
	HV60U4034CVA	25		24.3		327		135	462	
	HV60U4040CVA	30	20.1	7.9	9.7	35.3	DD.HV60.FR3.T12	373	152	525
	HV60U4052CVA	40				39.7		470	185	655
	HV60U4065CVA	50				44.1		600	232	832
	HV60U4077CVA	60	21.3	10.0	10.8	61.7	DD.HV60.FR4.T12	819	281	1,100
	HV60U4096CVA	75				66.2		973	332	1,305
	HV60U4124CVA	100				72.8		1,294	434	1,728

Table 25: 480 V IP55/UL Type 12 with Switch

Rated Input Voltage	Drive Catalog Code	Nominal HP	Physical Dimensions (in)			Weight (lb)	Drawing Number	Heat Loss (Watts)		
			H	W	D			Heatsink	Internal	Total
480 V 3-Phase	HV60U4005CTA	3	20.4	4.9	10.0	22.0	DD.HV60.FR1.T12.SW	39	39	79
	HV60U4008CTA	5				22.0		63	49	111
	HV60U4011CTA	7.5				22.0		142	61	203
	HV60U4014CTA	10				22.0		196	71	268
	HV60U4021CTA	15	24.5	10.5	28.7	DD.HV60.FR2.T12.SW	212	96	308	
	HV60U4027CTA	20			30.9		285	118	404	
	HV60U4034CTA	25			32.0		327	135	462	
	HV60U4040CTA	30	31.0	7.9	10.9	50.7	DD.HV60.FR3.T12.SW	373	152	525
	HV60U4052CTA	40				55.1		470	185	655
	HV60U4065CTA	50				59.5		600	232	832
	HV60U4077CTA	60	39.0	11.4	12.0	97.0	DD.HV60.FR4.T12.SW	819	281	1,100
	HV60U4096CTA	75				101.4		973	332	1,305

Table 26: 208 V IP20/Protected Chassis

Rated Input Voltage	Drive Catalog Code	Nominal HP	Physical Dimensions (in)			Weight (lb)	Drawing Number	Heat Loss (Watts)		
			H	W	D			Heatsink	Internal	Total
208 V 3-Phase	HV60U2211CBA	75	36.0	12.3	16.5	187.4	DD.HV60.FR9.IP20	1321	348	1,669
	HV60U2273CBA	100				196.2		1821	441	2,262

Table 27: 480 V IP20/Protected Chassis

Rated Input Voltage	Drive Catalog Code	Nominal HP	Physical Dimensions (in)			Weight (lb)	Drawing Number	Heat Loss (Watts)		
			H	W	D			Heatsink	Internal	Total
480 V 3-Phase	HV60U4180CBA	150	27.6	12.3	16.5	189.6	DD.HV60.FR9.IP20	1,707	413	2,120
	HV60U4240CBA	200				196.2		1,810	424	2,233
	HV60U4302CBA	250	31.5	17.3	18.6	295.4	DD.HV60.FR10.IP20	2,847	942	3,788

Table 28: UL Type 3R Leg Kit Weights

Catalog Code	Description	Lbs (Kg)
UUX002073	LEG KIT,18 INCH,HV600,W1,3R	22 (10)
UUX002078	LEG KIT,18 INCH,HV600,W2,3R	23 (10.5)
UUX002079	LEG KIT,18 INCH,HV600,W3,3R	24 (11)
UUX002080	LEG KIT,18 INCH,HV600,W4,3R	25 (11.3)
UUX002081	LEG KIT,30 INCH,HV600,W1,3R	37 (16.8)
UUX002082	LEG KIT,30 INCH,HV600,W2,3R	38 (17.3)
UUX002083	LEG KIT,30 INCH,HV600,W3,3R	40 (18.2)
UUX002084	LEG KIT,30 INCH,HV600,W4,3R	42 (19)

## Input and Output Reactors

### Input Reactors



1.5% and 3% impedance reactors may be used on the input of a drive to reduce the effect of line side transients on the drive. The reactors are available loose or in a separate Type 1 enclosure.

Table 29: Three-Phase, 208 V Input Reactors

HP	Catalog Code HV60U. . . .	1.5% Input		3% Input	
		Open	Type 1	Open	Type 1
		Part No.	Part No.	Part No.	Part No.
3	2011	URX000315	URX000418	URX000307	URX000413
5	2017	URX000319	URX000420	URX000311	URX000415
7.5	2024	URX000326	URX000424	URX000315	URX000418
10	2031	URX000332	URX000426	URX000319	URX000420
15	2046	URX000338	URX000428	URX000329	URX000501
20	2059	URX000341	URX000429	URX000332	URX000426
25	2075	URX000341	URX000429	URX000335	URX000427
30	2088	URX000344	URX000430	URX000338	URX000428
40	2114	URX000350	URX000432	URX000341	URX000429
50	2143	URX000353	URX000433	URX000344	URX000430
60	2169	URX000356	URX000434	URX000347	URX000431
75	2211	URX000359	URX000566	URX000350	URX000432
100	2273	URX000362	URX000580	URX000356	URX000434



Table 30: Three-Phase, 480 V Input Reactors

HP	Catalog Code HV60U. . . .	1.5% Input		3% Input	
		Open	Type 1	Open	Type 1
		Part No.	Part No.	Part No.	Part No.
3	4005	URX000299	URX000410	URX000300	URX000503
5	4008	URX000303	URX000411	URX000304	URX000504
7.5	4011	URX000307	URX000413	URX000308	URX000414
10	4014	URX000311	URX000415	URX000312	URX000416
15	4021	URX000315	URX000418	URX000316	URX000419
20	4027	URX000319	URX000420	URX000320	URX000421
25	4034	URX000319	URX000420	URX000320	URX000421
30	4040	URX000323	URX000422	URX000324	URX000423
40	4052	URX000326	URX000424	URX000327	URX000425
50	4065	URX000332	URX000426	URX000333	URX000554
60	4077	URX000335	URX000427	URX000336	URX000555
75	4096	URX000335	URX000427	URX000336	URX000555
100	4124	URX000341	URX000429	URX000342	URX000557
125	4156	URX000344	URX000430	URX000345	URX000558
150	4180	URX000347	URX000431	URX000348	URX000559
200	4240	URX000350	URX000432	URX000351	URX000560
250	4302	URX000353	URX000433	URX000354	URX000561

## Output Reactors



3% impedance reactors may be used on the output of a drive to reduce the effect of load side transients on the motor. The reactors are available loose or in a separate Type 1 enclosure.

Table 31: Three-Phase, 208 V Output Reactors

HP	Catalog Code HV60U. . . .	3% Output	
		Open	Type 1
		Part No.	Part No.
3	2011	05P00620-0134	05P00620-0032
5	2017	05P00620-0136	05P00620-0036
7.5	2024	URX000083	05P00620-0041
10	2031	05P00620-0044	05P00620-0046
15	2046	05P00620-0141	05P00620-0054
20	2059	05P00620-0143	05P00620-0058
25	2075	URX000085	URX000204
30	2088	URX000085	URX000204
40	2114	05P00620-0064	05P00620-0066
50	2143	05P00620-0069	URX000206
60	2169	URX000175	URX000248
75	2211	URX000175	URX000248
100	2273	URX000178	URX000249

Table 32: Three-Phase, 480 V Output Reactors

HP	Catalog Code HV60U. . . .	3% Output	
		Open	Type 1
		Part No.	Part No.
3	4005	05P00620-0025	05P00620-0029
5	4008	05P00620-0133	05P00620-0028
7.5	4011	05P00620-0135	05P00620-0033
10	4014	05P00620-0137	05P00620-0037
15	4021	05P00620-0138	05P00620-0042
20	4027	05P00620-0139	05P00620-0047
25	4034	05P00620-0139	05P00620-0047

HP	Catalog Code HV60U. . . .	3% Output	
		Open	Type 1
		Part No.	Part No.
30	4040	05P00620-0049	05P00620-0051
40	4052	05P00620-0142	05P00620-0055
50	4065	05P00620-0144	05P00620-0059
60	4077	05P00620-0144	05P00620-0059
75	4096	05P00620-0145	05P00620-0062
100	4124	05P00620-0013	05P00620-0067
125	4156	05P00620-0070	05P00620-0073
150	4180	URX000586	05P00620-0078
200	4240	URX000176	05P00620-0083
250	4302	URX000179	05P00620-0088

## Open Reactor Dimensions

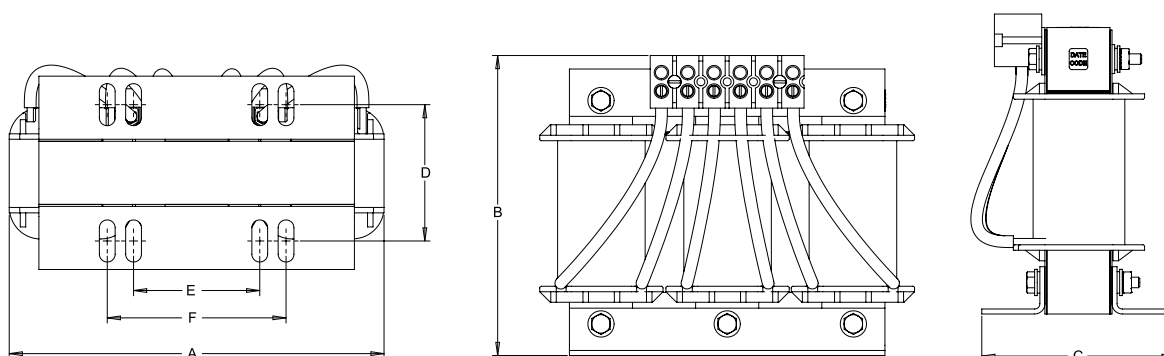

Table 33: Open Reactor Dimensions

Open Type Reactor Part number	Watt Loss	Dimensions (mm/in)						Weight kg/lb
		A	B	C	D	E	F	
05P00620-0013	180	229/9	183/7.2	172/6.8	93/3.7	92/3.6	N/A	28/62
05P00620-0025	25.3	152/6.0	122/4.8	86/3.4	67/2.6	51/2.0	N/A	5.0/11
05P00620-0044	49	183/7.2	147/5.8	102/4.0	66/2.6	76/3.0	N/A	6.4/14
05P00620-0049	62	229/9.0	188/7.4	119/4.7	80/3.2	76/3.0	N/A	13/28
05P00620-0064	108	229/9.0	179/7.1	118/4.7	80/3.2	76/3.0	N/A	13/29
05P00620-0069	116	229/9.0	183/7.2	172/6.8	80/3.2	92/3.6	N/A	19/42
05P00620-0070	149	274/10.8	277/8.3	152/6.0	88/3.5	92/3.6	N/A	23/51
05P00620-0133	29	152/6.0	122/4.8	76/3.0	53/2.1	51/2.0	N/A	3.6/8
05P00620-0134	26	152/6.0	127/5.0	84/3.3	53/2.1	51/2.0	N/A	4.1/9
05P00620-0135	31	152/6.0	127/5.0	84/3.3	53/2.1	51/2.0	N/A	4.5/10
05P00620-0136	36	152/6.0	135/5.3	81/3.2	54/2.1	51/2.0	N/A	4.1/9
05P00620-0137	43	152/6.0	135/5.3	89/3.5	63/2.5	51/2.0	N/A	5.5/12
05P00620-0138	52	183/7.2	147/5.8	89/3.5	60/2.4	76/3.0	N/A	6.4/14

Open Type Reactor Part number	Watt Loss	Dimensions (mm/in)						Weight
		A	B	C	D	E	F	kg/lb
05P00620-0139	54	183/7.2	147/5.8	102/4.0	70/2.8	76/3.0	N/A	7.3/16
05P00620-0141	64	229/9.0	176/7.0	135/5.4	80/3.2	76/3.0	N/A	10.9/24
05P00620-0142	67	229/9.0	178/7.0	135/5.3	80/3.2	76/3.0	N/A	12/27
05P00620-0143	82	229/9	183/7.2	160/6.3	88/3.5	92/3.6	N/A	20/43
05P00620-0144	86	229/9	183/7.2	165/6.5	88/3.5	92/3.6	N/A	23/51
05P00620-0145	84	229/9	185/7.3	173/6.8	93/3.7	92/3.6	N/A	23/51
URX000083	48	183/7.2	147/5.8	89/3.5	60/2.4	76/3.0	N/A	5.0/11
URX000085	94	229/9.0	185/7.3	165/6.5	88/3.4	92/3.6	N/A	21/47
URX000175	154	243.8/9.6	177.8/7	205.7/8.1	106/4.2	92/3.6	N/A	21.3/47
URX000176	231	274.3/10.8	215.9/8.5	193/7.6	131/5.2	117/4.6	N/A	36.3/80
URX000178	224	274.3/10.8	213.4/8.4	200.7/7.9	131/5.2	117/4.6	N/A	36.3/80
URX000179	264	274.3/10.8	213.4/8.4	226.1/8.9	149/5.9	117/4.6	N/A	46.3/102
URX000299	13.8	114/4.5	94/3.7	38/1.5	N/A	102/4.0	N/A	0.8/1.7
URX000300	23	114/4.5	94/3.7	38/1.5	N/A	102/4.0	N/A	0.8/1.8
URX000303	19.2	114/4.5	94/3.7	38/1.5	N/A	102/4.0	N/A	0.8/1.8
URX000304	37.2	112/4.4	127/5	71/2.8	51/2.0	36/1.4	N/A	1.3/2.8
URX000307	26.8	112/4.4	127/5	71/2.8	51/2.0	36/1.4	N/A	1.2/2.7
URX000308	40.9	112/4.4	127/5	79/3.1	53/2.1	36/1.4	N/A	1.9/4.2
URX000311	32.7	112/4.4	135/5.3	71/2.8	51/2.0	36/1.4	N/A	1.3/2.8
URX000312	48.2	112/4.4	127/5	79/3.1	53/2.1	36/1.4	N/A	2/4.3
URX000315	38.3	112/4.4	135/5.3	84/3.3	61/2.4	36/1.4	N/A	1.9/4.2
URX000316	57.4	152/6.0	155/6.1	74/2.9	N/A	102/4.0	N/A	3.3/7.2
URX000319	48.2	112/4.4	135/5.3	89/3.5	N/A	102/4.0	N/A	2.3/5.1
URX000320	66.8	152/6.0	155/6.1	84/3.3	N/A	102/4.0	N/A	4.3/9.5
URX000323	69	149.9/5.9	152.4/6.0	88.9/3.5	71.1/2.8	50.8/2.0	N/A	4.5/10
URX000324	102	183/7.2	152/6.0	95/3.8	N/A	102/4.0	N/A	5.9/13
URX000326	77	183/7.2	152/6.0	95/3.7	N/A	102/4.0	N/A	5.9/13
URX000327	99	183/7.2	152/6.0	109/4.3	N/A	102/4.0	N/A	7.7/17
URX000329	68	180.3/7.1	139.7/5.5	124.5/4.9	81.3/3.2	N/A	N/A	8.2/18
URX000332	87	183/7.2	152/6.0	102/4	N/A	102/4.0	N/A	8.2/18
URX000333	105	183/7.2	152/6.0	109/4.3	N/A	102/4.0	N/A	10/22
URX000335	119	183/7.2	152/6.0	109/4.3	N/A	102/4.0	N/A	8.6/19
URX000336	155	229/9.0	178/7.0	165/6.5	N/A	102/4.0	108/4.3	11.8/26
URX000338	94	183/7.2	152/6.0	165/6.5	70/2.8	76/3.0	108/4.3	10/22
URX000341	132	235/9.3	191/7.5	171/6.7	83/3.3	76/3.0	108/4.3	11.8/26
URX000342	152	235/9.3	191/7.5	171/6.7	95/3.8	76/3.0	108/4.3	16.8/37
URX000344	110	235/9.3	191/7.5	171/6.7	95/3.8	76/3.0	108/4.3	15.4/34
URX000345	195	235/9.3	191/7.5	210/8.3	121/4.8	76/3.0	108/4.3	22.2/49

Open Type Reactor Part number	Watt Loss	Dimensions (mm/in)						Weight
		A	B	C	D	E	F	kg/lb
URX000347	159	235/9.3	191/7.5	178/7.0	10/0.4	76/3.0	108/4.3	15.4/34
URX000348	224	235/9.3	191/7.5	210/8.3	121/4.8	76/3.0	108/4.3	22.2/49
URX000350	275	235/9.3	191/7.5	191/7.5	95/3.8	76/3.0	108/4.3	15.9/35
URX000351	284	235/9.3	191/7.5	216/8.5	121/4.8	76/3.0	108/4.3	24.9/55
URX000353	300	244/9.6	186/7.3	155/6.1	121/4.8	76.2/3.0	108/4.3	25.9/57
URX000354	383	274/10.8	222/8.7	216/8.5	136/5.4	92/3.6	142/5.6	34.5/76
URX000356	333	229/9.0	222/8.7	241/9.5	136/5.4	92/3.6	142/5.6	35.4/78
URX000359	314	274.3/10.8	213.4/8.4	223.5/8.8	137.2/5.4	91.4/3.6	142.2/5.6	36.7/81
URX000362	375	274.3/10.8	215.9/8.5	251.5/9.9	137.2/5.4	91.4/3.6	142.2/5.6	170.1/375
URX000586	168	244/9.6	183/7.3	201/7.9	112/4.4	92/3.7	108/4.3	24.5/54

## Type 1 (Enclosed) AC Reactor Dimensions

Figure 4: CAB-8

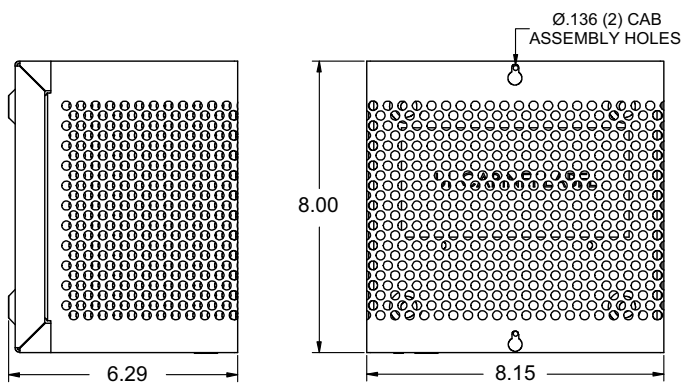

UNITS: INCHES

Figure 5: CAB-13V

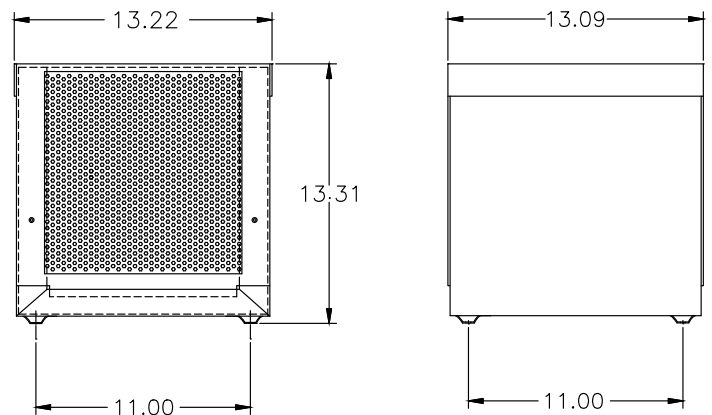

UNITS: INCHES

Figure 6: CAB-17V

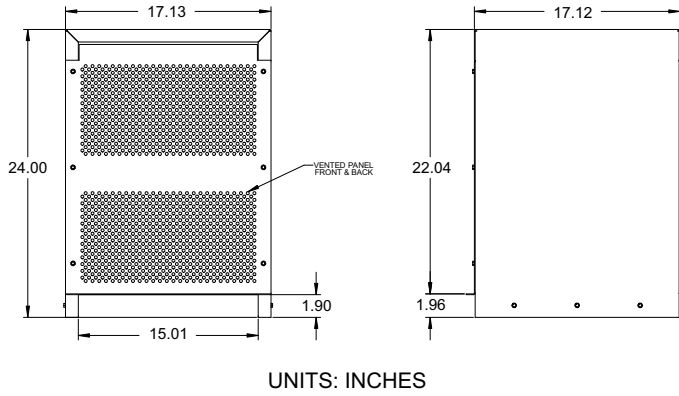

Figure 7: CAB-26C

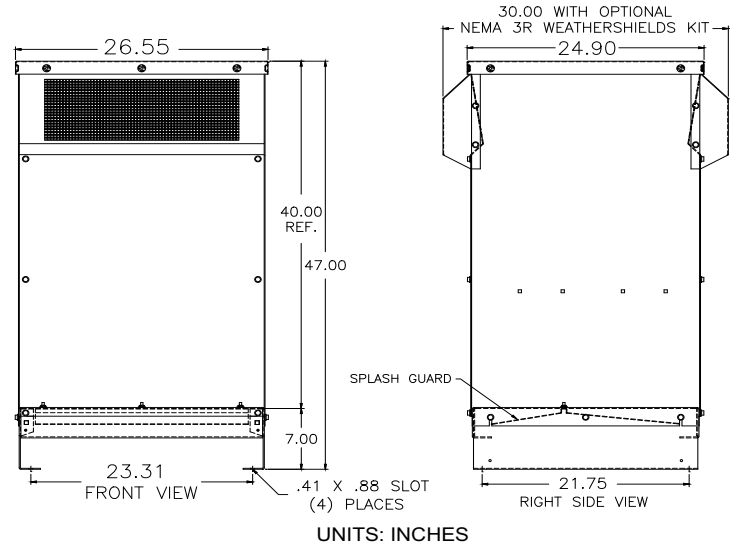

Table 34: Type 1 (Enclosed) Reactor Dimensions

Type 1 (Enclosed) Reactor Part number	Cabinet Reference (Figure)	Weight
		kg/lb
05P00620-0028	4	7/15
05P00620-0029		8/18
05P00620-0032		7/16
05P00620-0033		8/17
05P00620-0036		7/16
05P00620-0037		9/19
05P00620-0041		5
05P00620-0042	15/32	
05P00620-0046	15/32	
05P00620-0047	16/34	
05P00620-0050	19/41	
05P00620-0051	21/46	
05P00620-0055	20/45	
05P00620-0058	20/43	
05P00620-0059	23/51	
05P00620-0062	32/51	
05P00620-0066	6	21/47
05P00620-0067		28/61
05P00620-0073		31/68
05P00620-0078		33/72
05P00620-0083		49/107
05P00620-0088	65.8/145	

Type 1 (Enclosed) Reactor Part number	Cabinet Reference (Figure)	Weight
		kg/lb
URX000204	5	21/47
URX000206		27/59
URX000248		30/65
URX000249	6	49/107
URX000410	4	3.9/8.7
URX000411		4.0/8.8
URX000412		5.1/11.2
URX000414		5.1/11.2
URX000415		4.4/9.8
URX000416		5.1/11.3
URX000418	5	10/22.2
URX000419		11/25.2
URX000420		10/23.1
URX000421		12/27.5
URX000422		10.9/24
URX000423		14/31
URX000424		14/31
URX000425		14/31
URX000426		16/36
URX000427		17/37
URX000428		14/40
URX000429		20/44
URX000430		24/52
URX000431	6	28/61
URX000432		28/62
URX000433		45/100
URX000434	7	101/222
URX000501	5	15/32
URX000503	4	4.0/8.8
URX000504		3.6/8
URX000554	5	16.3/36
URX000555		20/44
URX000557		25/55
URX000558		30/67
URX000559	6	34/76
URX000560		37/82
URX000561	7	96.7/213
URX000566		98.9/218
URX000580		102/223

## Narrow Bypass, UL Type 1 (H6BP)



The HV600 Narrow Electronic Bypass is engineered for use in HVAC building automation applications that require reliable motor control. The package provides an HV600 drive above a UL Type 1 enclosure that houses a bypass to allow motor operation from the drive or across the line. The enclosure design is narrow, which conserves control room wall space.

The bypass features HVAC application-specific software macros, a Hand-Off-Auto LCD keypad, and a real-time clock for system accuracy. Popular building automation communication protocols BACnet, Siemens APOGEE, Johnson Controls Metasys, and MEMOBUS/Modbus are embedded in the drive. Interface cards for LonWorks, BACnet/IP and EtherNet/IP communications are offered separately.

Program the drive prior to installation and upgrade firmware without the need for three-phase main power. Use the free Yaskawa Drive Cloud with the DriveWizard Mobile Application for parameter backups and wired programming with an Android smart device.

### Performance Features

- VT Ratings:
  - 0.5 to 25 HP, 208 VAC
  - 0.5 to 60 HP, 480 VAC
- Overload capacity: 110% for 60 seconds (150% Peak)
- DC Injection braking: at start or stop, adjustable, current limited (anti-windmilling)
- Adjustable Accel/Decel: 0.1 to 6000 seconds
- Critical frequency rejection capability: 3 selectable, adjustable bands
- Auto restart after power loss or resettable fault, selectable, programmable
- Up/down control capability
- Stationary and rotational motor auto-tuning
- 140% starting torque capability, available from 3 Hz to 60 Hz
- Remote speed reference (speed command) signal:
  - 0 to 10 VDC (20 K Ohm)
  - 4 to 20 mA DC (250 Ohm)
- 8 programmable multi-function input terminals (24 VDC) providing 36+ programmable features, including:
  - Customer safeties
  - BAS / damper interlock
  - Emergency Override
  - Preset speed
  - PID control enable / disable
- 4 programmable multi-function output relays (Form C rated 2 amps @ 250 VAC & 30 VDC), providing 29+ functions, including:
  - Damper control
  - Hand/Auto status
  - Ready/Run/Fault status
  - Overtorque/Undertorque detection

### Bypass Features

- Bypass and Drive output contactors
- Standard configuration is a lockable main input disconnect switch and requires external branch circuit protection
- Adjustable electronic motor overload protection
- 115 VAC control transformer, fused
- Drive HOA keypad used for bypass control
- Damper control circuit with end of travel feedback and two adjustable wait time functions
- Selectable energy savings mode and harmonic reduction more
- No load detection (loss of load) fully monitored in drive and bypass modes.

### Service Conditions

- Input voltage:
  - 208 VAC, 480 VAC, -15/+10%
- Input frequency: 50/60 Hz  $\pm$  5%
- Ambient service temperature:
  - -10 °C to 40 °C (14 °F to 104 °F)
- Ambient storage temperature: -20 °C to 70 °C (-4 °F to 158 °F)
- Humidity: 0% to 95% non-condensing

### Design Features

- Built in 5% line impedance (0.5 - 25 HP @ 208 VAC, 0.75 - 60 HP @ 480 VAC)
- Displacement power factor of 0.98 throughout the motor speed range
- NEC rated input / output amps
- Internal EMI/RFI filter complies with IEC 61800-3 restricted distribution for first environment (Category 2)(0.5 - 25 HP @ 208 VAC, 0.75 - 60 HP @ 480 VAC)

- Built-In real-time clock for time and date stamping events along with timer functions for starting, stopping and speed changes without the need for external controls
- Volt meter, ammeter, kilowatt meter elapsed run time meter and heat sink temperature monitoring functions
- Drive internal PI closed-loop control with selectable engineering units
- Independent PI control for use with external device
- Differential PID feedback feature
- Direct or reverse acting speed signal
- Sleep function in both closed-loop and open-loop control
- Feedback signal loss detection and selectable response strategy
- Feedback signal inverse and square root capability
- 24 VDC, 150 mA power supply
- Input and output terminal status indication
- VFD efficiency: 98% at full-speed; 96% at half-speed
- Diagnostic fault indication
- S-curve soft start / soft stop capability
- Serial communication loss detection and selectable response strategy
- Serial communication status
- 9 preset speeds
- Built-in BACnet protocol (BTL certified)
  - BACnet Health Monitor feature for setup and troubleshooting
- Modbus/Memobus accessible via RS-422/485 communication, which is standard
- LCD keypad: Hand-Off-Auto functions with a built-in copy feature
- Flash upgradeable firmware



- Customizable monitor display
- Heat sink over temperature speed foldback feature
- Bumpless transfer between Hand and Auto modes
- Emergency override can be used as a Smoke Purge function
- Fan failure detection and selectable drive action
- Customer Analog Input speed reference for ease of wiring to the Bypass board

- BTL listed
- HCAI (OSHDP), IBC, ICC-ES AC156

**Ease of Use Features**

- LED Status Ring for clear drive operational status
- Programming and firmware upgrade without three-phase main power
- QR code for Yaskawa Drive Cloud registration
- Short circuit current rating (SCCR) on nameplate
- In box mounting templates and startup instructions

**Options**

- Circuit Breaker (100 kAIC, additional fuses not required)
- 3-Contactor Bypass
- Drive Service Switch
- Custom Nameplate
- BACnet/IP
- Ethernet/IP
- LonWorks
- Bluetooth®

**Standards**

- UL 508A (Industrial Control Panels)

# Catalog Code Configuration (H6BP)

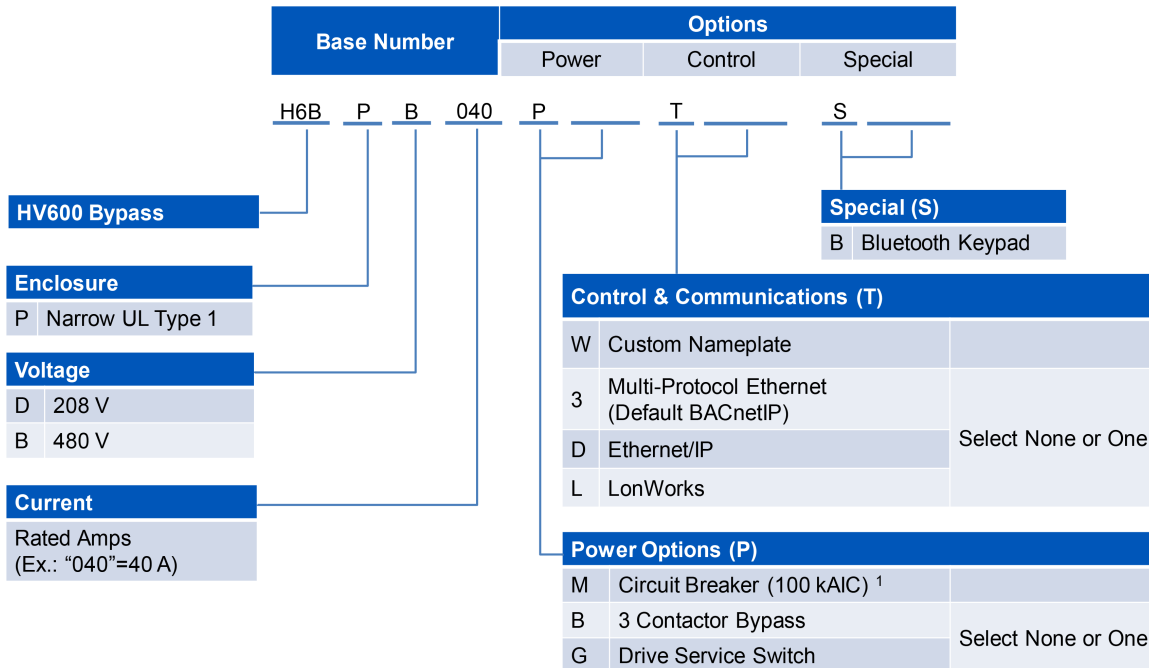

1. Drive input fuses are included in all Narrow Bypass packages with the PM (Circuit Breaker) option.

## Package Options (H6BP)

Table 35: Power Options

Option Code	Option	Description
M	Circuit Breaker	Option (M) is a 100 kAIC rated circuit breaker with fuses. When option (M) is specified, the bypass drive package will be rated at 100 kAIC. <sup>1</sup>
B	Drive Input Options	For a 3-contactor bypass that removes power from the drive, select option (B). Or, for a drive input service switch that removes power from the drive, select option (G).
G		

1. When option (M) is not selected, external branch circuit protection is required to achieve desired panel short circuit current rating (kAIC) and is supplied by the customer.

## Model Selection

Table 36: 208 V Models and Power Options

Rated Input Voltage	Rated Output Current (Amps)	Nominal HP <sup>1</sup>	UL Type 1 Bypass	Power Options		
			H6BP. . .	Circuit Breaker (100 kAIC) <sup>2</sup>	3 - Contactor Bypass	Drive Input Service Switch
				M	B	G
208 V 3-Phase	2.4	0.5	D002	-		
	3.5	0.75	D003			
	4.6	1	D004			
	7.5	2	D007			
	10.6	3	D010			
	16.7	5	D016			
	24.2	7.5	D024			
	30.8	10	D030			
	46.2	15	D046			
	59.4	20	D059			
74.8	25	D074				

1. Horsepower rating is based on standard NEMA B, 4-pole motor design as represented in NEC table 430.150 Full-Load Current, Three-Phase Alternating Current Motors at 208 volts.
2. Fuses are included in all Narrow Bypass packages with the PM option.

Table 37: 480 V Models and Power Options

Rated Input Voltage	Rated Output Current (Amps)	Nominal HP <sup>1</sup>	UL Type 1 Bypass	Power Options		
			H6BP. . .	Circuit Breaker (100 kAIC) <sup>2</sup>	3 - Contactor Bypass	Drive Input Service Switch
				M	B	G
480 V 3-Phase	1.6	0.75	B001	-		
	2.1	1	B002			
	3.2	2	B003			
	4.8	3	B004			
	7.6	5	B007			
	11	7.5	B011			
	14	10	B014			
	21	15	B021			
	27	20	B027			
	34	25	B034			
	40	30	B040			
	52	40	B052			
	65	50	B065			
	77	60	B077			

1. Horsepower rating is based on standard NEMA B, 4-pole motor design as represented in NEC table 430.150 Full-Load Current, Three-Phase Alternating Current Motors at 480 volts.
2. Fuses are included in all Narrow Bypass packages with the PM option.

Table 38: Control Options

Option Code	Option	Description
W	Custom Nameplate	Custom engraved nameplates with white lettering on black lamacoid are available with option (W), for special tagging purposes, for example, AHU#1. Note that this option requires the text to be specified by the customer.
3	Multi-Protocol Ethernet Card (BACnet/IP Dual Port)	Multi-Protocol Ethernet Card: BACnet/IP is the default setting.
D	EtherNet/IP Dual Port (SI-EN3D)	ODVA compliant option card to connect to EtherNet/IP.
L	LonWorks (SI-W3)	LonWorks, option (L), requires the addition of an optional board.
B	Bluetooth® Keypad	The Bluetooth® Enabled Keypad provides a wireless connection to your smartphone or tablet.

## Dimensions and Data

Table 39: 208 V UL Type 1 Packages

Rated Input Voltage	H6B Bypass Base No. H6BP. . .	Rated Output Current (Amps)	Nominal HP	Bypass Box No.	Submittal Documents (Outline Drawing) (Schematic) (Submittal Guide)	Drive Part No HV60U. . .	UL Type 1 Bypass Data			
							Overall Dimensions (in)			Weight (lb)
							H	W	D	
208 V 3-Phase	D002	2.4	0.5	W1	DD.HB.1.W1.01 DS.H6BP.01 SG.H6BP.10	2011CFA	41.6	6.9	14.7	55
	D003	3.5	0.75			2011CFA				
	D004	4.6	1			2011CFA				
	D007	7.5	2			2011CFA				
	D010	10.6	3			2011CFA				
	D016	16.7	5			2017CFA				
	D024	24.2	7.5	W2	DD.HB.1.W2.01 DS.H6BP.01 SG.H6BP.10	2024CFA	45.2			62
	D030	30.8	10			2031CFA				64
	D046	46.2	15	W3	DD.HB.1.W3.01 DS.H6BP.01 SG.H6BP.10	2046CFA	48.7	10.1	15.3	87
	D059	59.4	20			2059CFA				92
	D074	74.8	25	W4	DD.HB.1.W4.01 DS.H6BP.01 SG.H6BP.10	2075CFA	52.1	12.5	16.6	128

Table 40: 480 V UL Type 1 Packages

Rated Input Voltage	H6B Bypass Base No. H6BP	Rated Output Current (Amps)	Nominal HP	Bypass Box No.	Submittal Documents (Outline Drawing) (Schematic) (Submittal Guide)	Drive Part No HV60U. . . .	UL Type 1 Bypass Data			
							Overall Dimensions (in)			Weight (lb)
							H	W	D	
480 V	B1P1	1.1	0.50	W1	DD.HB.1.W1.01 DS.H6BP.01 SG.H6BP.10	4005CFA	41.6	6.9	14.7	56
	B001	1.6	0.75			4005CFA				
	B002	2.1	1			4005CFA				
	B003	3.2	2			4005CFA				
	B004	4.8	3			4005CFA				
	B007	7.6	5			4008CFA				
	B011	11	7.5			4011CFA				
	B014	14	10			4014CFA				
	B021	21	15	W2	DD.HB.1.W2.01 DS.H6BP.01 SG.H6BP.10	4021CFA	45.2			62
	B027	27	20			4027CFA				65
	B034	34	25	W3	DD.HB.1.W3.01 DS.H6BP.01 SG.H6BP.10	4034CFA	48.7	10.1	15.3	81
	B040	40	30			4040CFA				90
	B052	52	40			4052CFA				96
	B065	65	50	W4	DD.HB.1.W4.01 DS.H6BP.01 SG.H6BP.10	4065CFA	52.1	12.5	16.6	121
B077	77	60	4077CFA			135				

# Narrow Bypass, UL Type 12 (H6BN)



The HV600 Narrow Electronic Bypass is engineered for use in HVAC building automation applications that require reliable motor control. The package provides an HV600 drive above a UL Type 12 enclosure that houses a bypass to allow motor operation from the drive or across the line. The enclosure design is narrow, which conserves control room wall space.

The bypass features HVAC application-specific software macros, a Hand-Off-Auto LCD keypad, and a real-time clock for system accuracy. Popular building automation communication protocols BACnet, Siemens APOGEE, Johnson Controls Metasys, and MEMOBUS/Modbus are embedded in the drive. Interface cards for LonWorks, BACnet/IP, and EtherNet/IP communications are offered separately.

Program the drive prior to installation and upgrade firmware without the need for three-phase main power. Use the free Yaskawa Drive Cloud with the DriveWizard Mobile Application for parameter backups and wired programming with an Android smart device.

## Performance Features

- VT Ratings:
  - 0.5 to 20 HP, 208 VAC
  - 0.75 to 40 HP, 480 VAC
- Overload capacity: 110% for 60 seconds (150% Peak)
- DC Injection braking: at start or stop, adjustable, current limited (anti-windmilling)
- Adjustable Accel/Decel: 0.1 to 6000 seconds
- Critical frequency rejection capability: 3 selectable, adjustable bands
- Auto restart after power loss or resettable fault, selectable, programmable
- Up/down control capability
- Stationary and rotational motor auto-tuning
- 140% starting torque capability, available from 3 Hz to 60 Hz
- Remote speed reference (speed command) signal:
  - 0 to 10 VDC (20 K Ohm)
  - 4 to 20 mA DC (250 Ohm)
- 8 programmable multi-function input terminals (24 VDC) providing 36+ programmable features, including:
  - Customer safeties
  - BAS / damper interlock
  - Emergency Override
  - Preset speed
  - PID control enable / disable
- 4 programmable multi-function output relays (Form C rated 2 amps @ 250 VAC & 30 VDC), providing 29+ functions, including:
  - Damper control
  - Hand/Auto status
  - Ready/Run/Fault status
  - Overtorque/Undertorque detection

## Bypass Features

- Bypass and Drive output contactors
- Standard configuration is a lockable main input disconnect switch and requires external branch circuit protection
- Adjustable electronic motor overload protection
- 115 VAC control transformer, fused
- Drive HOA keypad used for bypass control
- Damper control circuit with end of travel feedback and two adjustable wait time functions
- Selectable energy savings mode and harmonic reduction more
- No load detection (loss of load) fully monitored in drive and bypass modes.

## Service Conditions

- Input voltage:
  - 208 VAC, 480 VAC, -15/+10%
- Input frequency: 50/60 Hz  $\pm$  5%
- Ambient service temperature:
  - -10 °C to 40°C (14 °F to 104 °F)
- Ambient storage temperature: -20 °C to 70 °C (-4 °F to 158 °F)
- Humidity: 0% to 95% non-condensing

## Design Features

- Built in 5% line impedance (0.5 - 25 HP @ 208 VAC, 0.75 - 60 HP @ 480 VAC)
- Displacement power factor of 0.98 throughout the motor speed range
- NEC rated input / output amps
- Internal EMI/RFI filter complies with IEC 61800-3 restricted distribution for first environment (Category 2)(0.5 - 25 HP @ 208 VAC, 0.75 - 60 HP @ 480 VAC)

- Built-In real-time clock for time and date stamping events along with timer functions for starting, stopping and speed changes without the need for external controls
- Volt meter, ammeter, kilowatt meter elapsed run time meter and heat sink temperature monitoring functions
- Drive internal PI closed-loop control with selectable engineering units
- Independent PI control for use with external device
- Differential PID feedback feature
- Direct or reverse acting speed signal
- Sleep function in both closed-loop and open-loop control
- Feedback signal loss detection and selectable response strategy
- Feedback signal inverse and square root capability
- 24 VDC, 150 mA power supply
- Input and output terminal status indication
- VFD efficiency: 98% at full-speed; 96% at half-speed
- Diagnostic fault indication
- S-curve soft start / soft stop capability
- Serial communication loss detection and selectable response strategy
- Serial communication status
- 9 preset speeds
- Built-in BACnet protocol (BTL certified)
  - BACnet Health Monitor feature for setup and troubleshooting
- Modbus/Memobus accessible via RS-422/485 communication, which is standard
- LCD keypad: Hand-Off-Auto functions with a built-in copy feature
- Flash upgradeable firmware

- Customizable monitor display
- Heat sink over temperature speed foldback feature
- Bumpless transfer between Hand and Auto modes
- Emergency override can be used as a Smoke Purge function
- Fan failure detection and selectable drive action
- Customer Analog Input speed reference for ease of wiring to the Bypass board

- BTL listed

### Ease of Use Features

- LED Status Ring for clear drive operational status
- Programming and firmware upgrade without three-phase main power
- QR code for Yaskawa Drive Cloud registration
- Short circuit current rating (SCCR) on nameplate
- In box mounting templates and startup instructions

### Options

- Circuit Breaker (100 kAIC, additional fuses not required)
- 3-Contactor Bypass
- Drive Service Switch
- Custom Nameplate
- BACnet/IP
- Ethernet/IP
- LonWorks
- Bluetooth®

### Standards

- UL 508A (Industrial Control Panels)

## Catalog Code Configuration (H6BN)

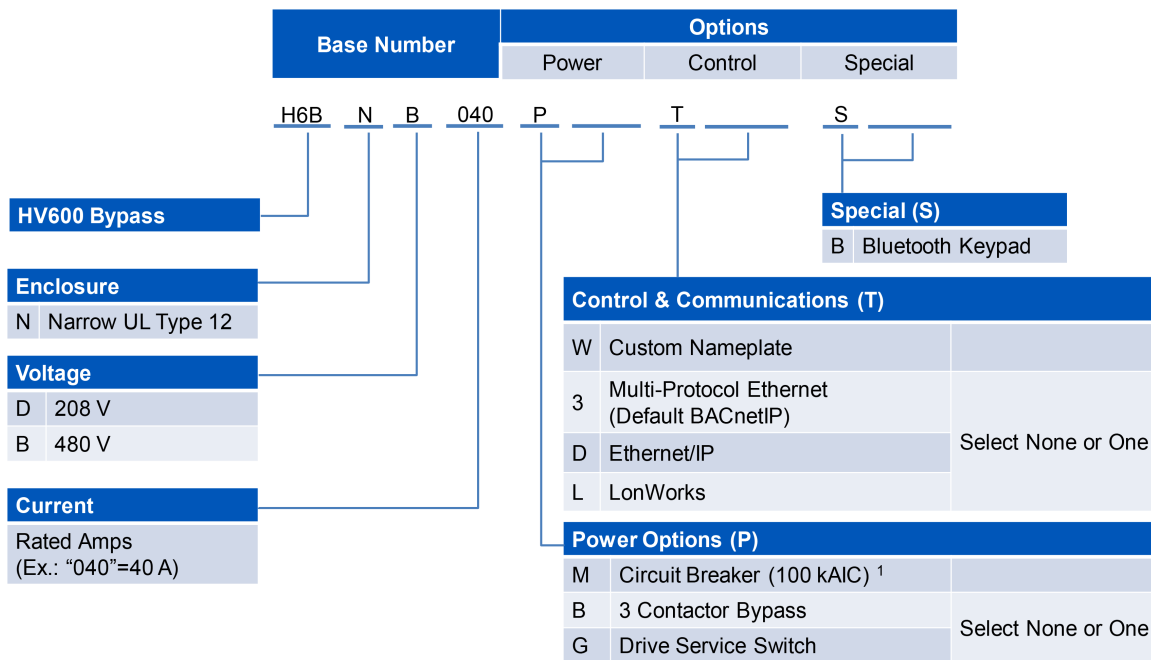

1. Drive input fuses are included in all Narrow Bypass packages with the PM (Circuit Breaker) option.

## Package Options (H6BN)

Table 41: Power Options

Option Code	Option	Description
M	Circuit Breaker	Option (M) is a 100 kAIC rated circuit breaker with fuses. When option (M) is specified, the bypass drive package will be rated at 100 kAIC. <sup>1</sup>
B	Drive Input Options	For a 3-contactor bypass that removes power from the drive, select option (B). Or, for a drive input service switch that removes power from the drive, select option (G).
G		

1. When option (M) is not selected, external branch circuit protection is required to achieve desired panel short circuit current rating (kAIC) and is supplied by the customer.

## Model Selection

Table 42: 208 V Models and Power Options

Rated Input Voltage	Rated Output Current (Amps)	Nominal HP <sup>1</sup>	UL Type 1 Bypass	Power Options		
				Circuit Breaker (100 kAIC) <sup>2</sup>	3 - Contactor Bypass	Drive Input Service Switch
			H6BP. . .	M	B	G
208 V 3-Phase	2.4	0.5	D002	-		
	3.5	0.75	D003			
	4.6	1	D004			
	7.5	2	D007			
	10.6	3	D010			
	16.7	5	D016			
	24.2	7.5	D024			
	30.8	10	D030			
	46.2	15	D046			
	59.4	20	D059			
74.8	25	D074				

1. Horsepower rating is based on standard NEMA B, 4-pole motor design as represented in NEC table 430.150 Full-Load Current, Three-Phase Alternating Current Motors at 208 volts.
2. Fuses are included in all Narrow Bypass packages with the PM option.

Table 43: 480 V Models and Power Options

Rated Input Voltage	Rated Output Current (Amps)	Nominal HP <sup>1</sup>	UL Type 1 Bypass	Power Options		
				Circuit Breaker (100 kAIC) <sup>2</sup>	3 - Contactor Bypass	Drive Input Service Switch
			H6BP. . .	M	B	G
480 V 3-Phase	1.6	0.75	B001	-		
	2.1	1	B002			
	3.2	2	B003			
	4.8	3	B004			
	7.6	5	B007			
	11	7.5	B011			
	14	10	B014			
	21	15	B021			
	27	20	B027			
	34	25	B034			
	40	30	B040			
	52	40	B052			
	65	50	B065			
	77	60	B077			

1. Horsepower rating is based on standard NEMA B, 4-pole motor design as represented in NEC table 430.150 Full-Load Current, Three-Phase Alternating Current Motors at 480 volts.
2. Fuses are included in all Narrow Bypass packages with the PM option.

Table 44: Control Options

Option Code	Option	Description
W	Custom Nameplate	Custom engraved nameplates with white lettering on black lamacoid are available with option (W), for special tagging purposes, for example, AHU#1. Note that this option requires the text to be specified by the customer.
3	Multi-Protocol Ethernet Card (BACnet/IP Dual Port)	Multi-Protocol Ethernet Card: BACnet/IP is the default setting.
D	EtherNet/IP Dual Port (SI-EN3D)	ODVA compliant option card to connect to EtherNet/IP.
L	LonWorks (SI-W3)	LonWorks, option (L), requires the addition of an optional board.
B	Bluetooth® Keypad	The Bluetooth® Enabled Keypad provides a wireless connection to your smartphone or tablet.

## Dimensions and Data

Table 45: 208 V UL Type 12 Packages

Rated Input Voltage	H6B Bypass Base No. H6BN...	Rated Output Current (Amps)	Nominal HP	Bypass Box No.	Submittal Documents (Outline Drawing) (Schematic) (Submittal Guide)	Drive Part No HV60U. . . .	UL Type 12 Bypass Data			
							Overall Dimensions (in)			Weight (lb)
							H	W	D	
208 V 3-Phase	D002	2.4	0.5	W1	DD.HB.12.W1.01 DS.H6BN.01 SG.H6BN.10	2011CVA	46.1	7.7	14.0	73
	D003	3.5	0.75			2011CVA				
	D004	4.6	1			2011CVA				
	D007	7.5	2			2011CVA				
	D010	10.6	3			2011CVA				
	D016	16.7	5			2017CVA				
	D024	24.2	7.5	W2	DD.HB.12.W2.01 DS.H6BN.01 SG.H6BN.10	2024CVA	49.7			79
	D030	30.8	10			2031CVA				83
	D046	46.2	15	W3	DD.HB.12.W3.01 DS.H6BN.01 SG.H6BN.10	2046CVA	52.6	10.8	14.6	112
	D059	59.4	20			2059CVA				117



Table 46: 480 V UL Type 12 Packages

Rated Input Voltage	H6B Bypass Base No. H6BN....	Rated Output Current (Amps)	Nominal HP	Bypass Box No.	Submittal Documents (Outline Drawing) (Schematic) (Submittal Guide)	Drive Part No HV60U. . . .	UL Type 12 Bypass Data			
							Overall Dimensions (in)			Weight (lb)
							H	W	D	
480 V	B001	1.6	0.75	W1	DD.HB.12.W1.01 DS.H6BN.01 SG.H6BN.10	4005CVA	46.1	7.7	14.0	74
	B002	2.1	1			4005CVA				
	B003	3.4	2			4005CVA				
	B004	4.8	3			4005CVA				
	B007	7.6	5			4008CVA				
	B011	11	7.5			4011CVA				
	B014	14	10			4014CVA				
	B021	21	15	W2	DD.HB.12.W2.01 DS.H6BN.01 SG.H6BN.10	4021CVA	49.7			82
	B027	27	20			4027CVA				84
	B034	34	25	W3	DD.HB.12.W3.01 DS.H6BN.01 SG.H6BN.10	4034CVA	52.6	10.8	14.6	104
	B040	40	30			4040CVA				115
	B052	52	40			4052CVA				122

## Enclosed Bypass, UL Type 1 (H6B1)



Enclosed Bypass features the HV600 drive and all bypass components housed in a UL Type 1 certified enclosure.

Every HV600 comes with HVAC application-specific software presets, a Hand-Off-Auto LCD keypad, a high-visibility Status Ring for quick visual indication of drive status, and a real-time clock for system accuracy. Popular building automation communication protocols BACnet, Siemens APOGEE, Johnson Controls Metasys, and MEMOBUS/Modbus are embedded in the drive. Interface cards for Modbus TCP/IP, LonWorks, BACnet/IP, and EtherNet/IP communications are offered separately.

Program the drive prior to installation and upgrade firmware without the need for three-phase main power. Use the free Yaskawa Drive Cloud with the DriveWizard Mobile Application for parameter backups and wired programming with an Android smart device.

### Performance Features

- VT Ratings:
  - 0.5 to 100 HP, 208 VAC
  - 0.5 to 100 HP, 240 VAC
  - 0.5 to 250 HP, 480 VAC
- Overload capacity: 110% for 60 seconds (150% Peak)
- DC Injection braking: at start or stop, adjustable, current limited (anti-windmilling)
- Motor preheat function
- Adjustable Accel/Decel: 0.1 to 6000 seconds
- Controlled speed range: 40:1 (V/f)
- Maximum output frequency: 400 Hz
- Safe Torque Off: SIL3, PLc
- 24 VDC power output to power sensors and other devices (150 mA)
- 24 VDC external power input to maintain network communications and allow for keypad programming and monitoring during a three-phase power loss
- Temperature controlled fans
- Critical frequency rejection capability: 3 selectable, adjustable bands
- Torque limiting: 30 to 180%
- Power loss ride-through: 2 seconds
- Auto restart after power loss or resettable fault, selectable, programmable
- Serial communications loss detection
- Stationary and rotational motor auto-tuning
- 140% starting torque capability, available from 3 Hz to 60 Hz

- Remote speed reference (speed command) signal:
  - 0 to 10 VDC (20 K Ohm)
  - 0 to 20 mA DC (250 Ohm)
  - 4 to 20 mA DC (250 Ohm)
- 8 programmable multi-function input terminals (24 VDC) providing 36+ programmable features, including:
  - Customer safeties
  - BAS / damper interlock
  - Emergency Override
  - Preset speed
  - PID control enable / disable
- 4 programmable multi-function output relays (Form C rated 2 amps @ 250 VAC & 30 VDC), providing 29+ functions, including:
  - Damper control
  - Hand/Auto status
  - Ready/Run/Fault status
  - Overtorque/Undertorque detection

- No load detection (loss of load) fully monitored in drive and bypass modes.

### Service Conditions

- Input voltage:
  - 208 VAC, 240 VAC, 480 VAC, -15/+10%
- Input frequency: 50/60 Hz  $\pm$ 5%
- Ambient service temperature:
  - -10 °C to 40 °C (14 °F to 104 °F)
- Ambient storage temperature: -20°C to 70°C (-4 °F to 158 °F)
- Humidity: 0% to 95% non-condensing
- RoHS 2 compliant
- Conformal coating (IEC 60721-3-3, IP20/UL Type 1: 3C2, 3S2; IP55/UL Type 12: 3C2, 3S3)

### Design Features

- Built in 5% line impedance (0.5 - 100 HP @ 208 VAC, 0.5 to 100 HP @ 240 VAC, 0.75 - 250 HP @ 480 VAC)
- Displacement power factor of 0.98 throughout the motor speed range
- NEC rated input / output amps
- Internal EMI/RFI filter complies with IEC 61800-3 restricted distribution for first environment (Category 2) (0.5 - 100 HP @ 208 VAC, 0.5 - 100 HP @ 240 VAC, 0.75 to 250 HP @ 480 VAC)
- Built-In real-time clock for time and date stamping events along with timer functions for starting, stopping and speed changes without the need for external controls
- Volt meter, ammeter, kilowatt meter elapsed run time meter and heat sink temperature monitoring functions

### Bypass Features

- Bypass and Drive output contactors
- Standard configuration is a lockable main input disconnect switch and requires external branch circuit protection
- Adjustable electronic motor overload protection
- 115 VAC control transformer, fused
- Drive HOA keypad used for bypass control
- Damper control circuit with end of travel feedback and two adjustable wait time functions
- Selectable energy savings mode and harmonic reduction more

- Drive internal PI closed-loop control with selectable engineering units
- Independent PI control for use with external device
- Differential PID feedback feature
- Direct or reverse acting speed signal
- Sleep function in both closed-loop and open-loop control
- Feedback signal loss detection and selectable response strategy
- Feedback signal inverse and square root capability
- 24 VDC, 150 mA power supply
- Input and output terminal status indication
- VFD efficiency: 98% at full-speed; 96% at half-speed
- Diagnostic fault indication
- S-curve soft start / soft stop capability
- Serial communication loss detection and selectable response strategy
- Serial communication status
- 9 preset speeds
- Built-in BACnet protocol (BTL certified)

- BACnet Health Monitor feature for setup and troubleshooting
- Modbus/Memobus accessible via RS-422/485 communication, which is standard
- LCD keypad: Hand-Off-Auto functions with a built-in copy feature
- Flash upgradeable firmware
- Customizable monitor display
- Heat sink over temperature speed foldback feature
- Bumples transfer between Hand and Auto modes
- Emergency override can be used as a Smoke Purge function
- Fan failure detection and selectable drive action
- Customer Analog Input speed reference for ease of wiring to the Bypass board

### Standards

- UL 508A (Industrial Control Panels)
- BTL Certified
- HCAI (OSHDP), IBC, ICC-ES AC156
- Seismic certification is for wall mounted units only

### Ease of Use Features

- Programming and firmware upgrade without three-phase main power
- QR code for Yaskawa Drive Cloud registration
- Short circuit current rating (SCCR) on nameplate
- In box mounting templates and startup instructions

### Options

- Circuit Breaker (100 kAIC, additional fuses not required)
- Drive Input Fuses
- Drive Service Switch
- 3-Contactor Bypass Switch
- Custom Nameplate
- BACnet/IP
- Ethernet/IP
- LonWorks
- Speed Pot
- Control Transformer (200 VA extra)
- Bluetooth®

## Catalog Code Configuration (H6B1)

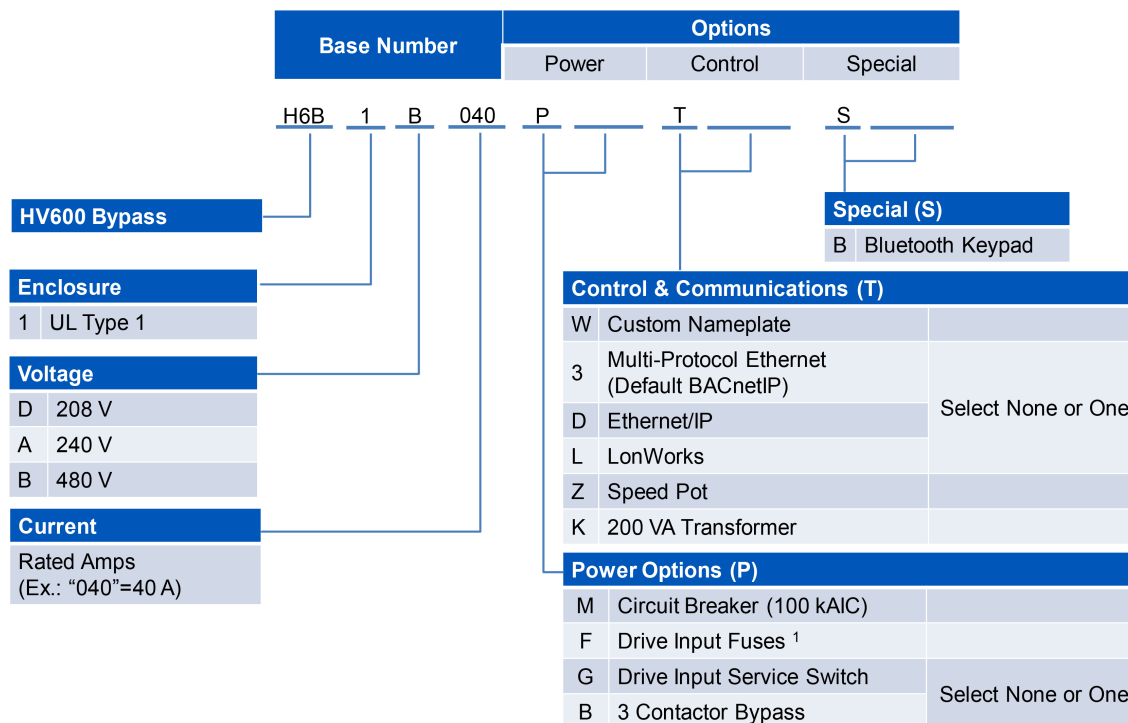

1. For drive input fuses, choose Option F. Option F is not allowed with Option M for the following packages because drive input fusing is automatically included: H6B1D211, H6B1D273, H6B1A192, H6B1A248, H6B1B180, H6B1B240, H6B1B302.

## Package Options (H6B1)

Table 47: Power Options

Option Code	Option	Description
M	Circuit Breaker	Option (M) is a 100 kAIC rated circuit breaker. When option (M) is specified, the bypass drive package will be rated at 100 kAIC. <sup>1</sup>
F	Input Fuses	This option (F) provides input fuses for drive short circuit protection. <sup>2</sup>
B	Drive Input Options	The standard configuration does not include a disconnecting means specifically for the drive. For a 3-contactor bypass that removes power from the drive, select option (B). Or, for a drive input service switch that removes power from the drive, select option (G).
G		

1. When option (M) is not selected, external branch circuit protection is required to achieve desired panel short circuit current rating (kAIC) and is supplied by the customer.
2. Drive input fuses provide short circuit current protection (100kAIC) for the drive and allows for a wider range of external branch circuit protection options supplied by the customer.

## Model Selection

Table 48: 208 V Models and Power Options

Rated Input Voltage	Rated Output Current (Amps)	Nominal HP <sup>1</sup>	UL Type1 Bypass	Power Options			
				Circuit Breaker (100 kAIC)	Input Fuses	3 - Contactor Bypass	Drive Input Service Switch
			H6B1. . . .	M	F	B	G
208 V 3-Phase	2.4	0.5	D002				
	3.5	0.75	D003				
	4.6	1	D004				
	7.5	2	D007				
	10.6	3	D010				
	16.7	5	D016				
	24.2	7.5	D024				
	30.8	10	D030				
	46.2	15	D046				
	59.4	20	D059				
	74.8	25	D074				
	88	30	D088				
	114	40	D114				
	143	50	D143				
	169	60	D169				
211	75	D211					
273	100	D273					

1. Horsepower rating is based on standard NEMA B, 4-pole motor design as represented in NEC table 430.150 Full Load Current, Three- Phase Alternating Current Motors at 208 volts.

Table 49: 240 V Models and Power Options

Rated Input Voltage	Rated Output Current (Amps)	Nominal HP <sup>1</sup>	UL Type 1 Bypass	Power Options			
				Circuit Breaker (100 kAIC)	Input Fuses	3 - Contactor Bypass	Drive Input Service Switch
			H6B1. . . .	M	F	B	G
240 V 3-Phase	2.2	0.5	A002				
	3.2	0.75	A003				
	4.2	1	A004				
	6.8	2	A006				
	9.6	3	A009				
	15.2	5	A015				
	22	7.5	A022				
	28	10	A028				
	42	15	A042				
	54	20	A054				
	68	25	A068				
	80	30	A080				
	104	40	A104				
	130	50	A130				
	154	60	A154				
	192	75	A192				
248	100	A248					

1. Horsepower rating is based on standard NEMA B, 4-pole motor design as represented in NEC table 430.150 Full Load Current, Three- Phase Alternating Current Motors at 240 volts.

Table 50: 480 V Models and Power Options

Rated Input Voltage	Rated Output Current (Amps)	Nominal HP <sup>1</sup>	UL Type 1 Bypass	Power Options			
				Circuit Breaker (100 kAIC)	Input Fuses	3 - Contactor Bypass	Drive Input Service Switch
			H6B1. . . .	M	F	B	G
480 V 3-Phase	1.6	0.75	B001				
	2.1	1	B002				
	3.4	2	B003				
	4.8	3	B004				
	7.6	5	B007				
	11	7.5	B011				
	14	10	B014				
	21	15	B021				
	27	20	B027				
	34	25	B034				
	40	30	B040				
	52	40	B052				
	65	50	B065				
	77	60	B077				
	96	75	B096				
	124	100	B124				
	156	125	B156				
180	150	B180					
240	200	B240					
302	250	B302					

1. Horsepower rating is based on standard NEMA B, 4-pole motor design as represented in NEC table 430.150 Full Load Current, Three- Phase Alternating Current Motors at 480 volts.

Table 51: Control Options

Option Code	Option	Description
W	Customer Nameplate	Custom engraved nameplates with white lettering on black lamicaid are available with option (W), for special tagging purposes (Example: AHU#1). Note that this option requires the text to be specified by the customer.
3	Multi-Protocol Ethernet Card (BACnet/IP Dual Port)	Multi-Protocol Ethernet Card: BACnet/IP is the default setting.
D	EtherNet/IP Dual Port (SI-EN3D)	ODVA compliant option card to connect to EtherNet/IP.
L	LonWorks (SI-W3)	LonWorks option (L), requires the addition of an optional board.
Z	Speed Pot	This option provides a door-mounted Speed Pot with knob to control motor speed.
K	200 VA Transformer	200 VA Control Power Transformer (for customer use).
B	Bluetooth® Keypad	The Bluetooth® Enabled Keypad provides a wireless connection to your smartphone or tablet.

## Dimensions and Data (H6B1)

Table 52: 208 V UL Type 1

Rated Input Voltage	H6B Bypass Base No. H6B1....	Rated Output Current (Amps)	Nominal HP	Bypass Box No.	Submittal Documents (Outline Drawing) (Schematic) (Submittal Guide)	Drive Part No HV60U....	Enclosed, UL Type 1 Bypass Data			
							Overall Dimensions (in)			Weight (lb)
							H	W	D	
208 V 3-Phase	D002	2.4	0.5	W0	DD.HWF.1.W0.01 DS.H6B1.01 SG.H6B1.10	2011CFA	25.9	15.7	15.6	93
	D003	3.5	0.75			2011CFA				
	D004	4.6	1			2011CFA				
	D007	7.5	2			2011CFA				
	D010	10.6	3			2011CFA				
	D016	16.7	5			2017CFA				
	D024	24.2	7.5	W1	DD.HWF.1.W1.01 DS.H6B1.01 SG.H6B1.10	2024CFA	33.9	18.7	17.6	125
	D030	30.8	10			2031CFA				128
	D046	46.2	15	W2	DD.HWF.1.W2.01 DS.H6B1.01 SG.H6B1.10	2046CFA	37.1	20.8	18.5	159
	D059	59.4	20			2059CFA				163
	D074	74.8	25	W3	DD.HWF.1.W3.01 DS.H6B1.01 SG.H6B1.10	2075CFA	42.1	25.6	18.9	224
	D088	88	30			2088CFA				233
	D114	114	40			2114CFA				248
	D143	143	50	W4	DD.HWF.1.W4.01 DS.H6B1.01 SG.H6B1.10	2143CFA	53.1	33.8	20.5	419
	D169	169	60			2169CFA				434
	D211	211	75	F1 <sup>1</sup>	DD.HWF.1.F1.01 DS.H6B1.01 SG.H6B1.10	2211CBA	87.0	42.0	33.5	832
	D273	273	100			2273CBA				859

1. Floor-mount enclosures are not seismic certified.

Table 53: 240 V UL Type 1

Rated Input Voltage	H6B Bypass Base No. H6B1....	Rated Output Current (Amps)	Nominal HP	Bypass Box No.	Submittal Documents (Outline Drawing) (Schematic) (Submittal Guide)	Drive Part No HV60U....	Enclosed, UL Type 1 Bypass Data			
							Overall Dimensions (in)			Weight (lb)
							H	W	D	
240 V 3-Phase	A002	2.2	0.5	W0	DD.HWF.1.W0.01 DS.H6B1.01 SG.H6B1.10	2011CFA	25.9	15.7	15.6	93
	A003	3.2	0.75			2011CFA				
	A004	4.2	1			2011CFA				
	A006	6.8	2			2011CFA				
	A009	9.6	3			2011CFA				
	A015	15.2	5			2017CFA				
	A022	22	7.5	W1	DD.HWF.1.W1.01 DS.H6B1.01 SG.H6B1.10	2024CFA	33.9	18.7	17.6	125
	A028	28	10			2031CFA				128
	A042	42	15	W2	DD.HWF.1.W2.01 DS.H6B1.01 SG.H6B1.10	2046CFA	37.1	20.8	18.5	159
	A054	54	20			2059CFA				163
	A068	68	25	W3	DD.HWF.1.W3.01 DS.H6B1.01 SG.H6B1.10	2075CFA	42.1	25.6	18.9	224
	A080	80	30			2088CFA				228
	A104	104	40			2114CFA				243
	A130	130	50	W4	DD.HWF.1.W4.01 DS.H6B1.01 SG.H6B1.10	2143CFA	53.1	33.8	20.5	414
	A154	154	60			2169CFA				430
	A192	192	75	F1 <sup>1</sup>	DD.HWF.1.F1.01 DS.H6B1.01 SG.H6B1.10	2211CBA	87.0	42.0	33.5	803
	A248	248	100			2273CBA				859

1. Floor-mount enclosures are not seismic certified.



Table 54: 480 V UL Type 1

Rated Input Voltage	H6B Bypass Base No. H6B1....	Rated Output Current (Amps)	Nominal HP	Bypass Box No.	Submittal Documents (Outline Drawing) (Schematic) (Submittal Guide)	Drive Part No HV60U....	Enclosed, UL Type 1 Bypass Data				
							Overall Dimensions (in)			Weight (lb)	
							H	W	D		
480 V 3-Phase	B1P1	1.1	0.5	W0	DD.HWF.1.W0.01 DS.H6B1.01 SG.H6B1.10	4005CFA	25.9	15.7	15.6	93	
	B001	1.6	0.75			4005CFA					
	B002	2.1	1			4005CFA					
	B003	3.4	2			4005CFA					
	B004	4.8	3			4005CFA					
	B007	7.6	5			4008CFA					
	B011	11	7.5			4011CFA					
	B014	14	10			4014CFA				94	
	B021	21	15	4021CFA							
	B027	27	20	W1	DD.HWF.1.W1.01 DS.H6B1.01 SG.H6B1.10	4027CFA	33.9	18.7	17.6	125	
	B034	34	25			4034CFA				129	
	B040	40	30	W2	DD.HWF.1.W2.01 DS.H6B1.01 SG.H6B1.10	4040CFA				37.1	20.8
	B052	52	40			4052CFA	162				
	B065	65	50			4065CFA	168				
	B077	77	60	W3	DD.HWF.1.W3.01 DS.H6B1.01 SG.H6B1.10	4077CFA	42.1	25.6	18.9	179	
	B096	96	75			4096CFA				233	
	B124	124	100			4124CFA				247	
	B156	156	125	W4	DD.HWF.1.W4.01 DS.H6B1.01 SG.H6B1.10	4156CFA	53.1	33.8	20.5	263	431
	B180	180	150	F1 <sup>1</sup>	DD.HWF.1.F1.01 DS.H6B1.01 SG.H6B1.10	4180CBA	87.0	42.0	33.5	803	
	B240	240	200			4240CBA				857	
B302	302	250	4302CBA			964					

1. Floor-mount enclosures are not seismic certified.

## Enclosed Bypass, UL Type 12 (H6B2)



Enclosed Bypass features the HV600 drive and all bypass components housed in a UL Type 12 certified enclosure.

Every HV600 comes with HVAC application-specific software presets, a Hand-Off-Auto LCD keypad, a high-visibility Status Ring for quick visual indication of drive status, and a real-time clock for system accuracy. Popular building automation communication protocols BACnet, Siemens APOGEE, Johnson Controls Metasys, and MEMOBUS/Modbus are embedded in the drive. Interface cards for Modbus TCP/IP, LonWorks, BACnet/IP, and EtherNet/IP communications are offered separately.

Program the drive prior to installation and upgrade firmware without the need for three-phase main power. Use the free Yaskawa Drive Cloud with the DriveWizard Mobile Application for parameter backups and wired programming with an Android smart device.

### Performance Features

- VT Ratings:
  - 0.5 to 100 HP, 208 VAC
  - 0.5 to 100 HP, 240 VAC
  - 0.5 to 250 HP, 480 VAC
- Overload capacity: 110% for 60 seconds (150% Peak)
- DC Injection braking: at start or stop, adjustable, current limited (anti-windmilling)
- Motor preheat function
- Adjustable Accel/Decel: 0.1 to 6000 seconds
- Controlled speed range: 40:1 (V/f)
- Maximum output frequency: 400 Hz
- Safe Torque Off: SIL3, PLe
- 24 VDC power output to power sensors and other devices (150 mA)
- 24 VDC external power input to maintain network communications and allow for keypad programming and monitoring during a three-phase power loss
- Temperature controlled fans
- Critical frequency rejection capability: 3 selectable, adjustable bands
- Torque limiting: 30 to 180%
- Power loss ride-through: 2 seconds
- Auto restart after power loss or resettable fault, selectable, programmable
- Up/down speed control capability (digital MOP)
- Serial communications loss detection
- Stationary and rotational motor auto-tuning

- 140% starting torque capability, available from 3 Hz to 60 Hz
- Remote speed reference (speed command) signal:
  - 0 to 10 VDC (20 K Ohm)
  - 4 to 20 mA DC (250 Ohm)
- 8 programmable multi-function input terminals (24 VDC) providing 36+ programmable features, including:
  - Customer safeties
  - BAS / damper interlock
  - Emergency Override
  - Preset speed
  - PID control enable / disable
- 4 programmable multi-function output relays (Form C rated 2 amps @ 250 VAC & 30 VDC), providing 29+ functions, including:
  - Damper control
  - Hand/Auto status
  - Ready/Run/Fault status
  - Overtorque/Undertorque detection

- No load detection (loss of load) fully monitored in drive and bypass modes.

### Service Conditions

- Input voltage:
  - 208 VAC, 240 VAC, 480 VAC, -15/+10%
- Input frequency: 50/60 Hz ±5%
- Ambient service temperature:
  - -10 °C to 40 °C (14 °F to 104 °F)
- Ambient storage temperature: -20 °C to 70 °C (-4 °F to 158 °F)
- Humidity: 0% to 95% non-condensing

### Design Features

- Built in 5% line impedance (0.5 - 100 HP @ 208 VAC, 0.5 - 100 HP @ 240 VAC, 0.75 - 250 HP @ 480 VAC)
- Displacement power factor of 0.98 throughout the motor speed range
- NEC rated input / output amps
- Internal EMI/RFI filter complies with IEC 61800-3 restricted distribution for first environment (Category 2) (0.5 - 100 HP @ 208 VAC, 0.5 - 100 HP @ 240 VAC, 0.75 - 250 HP @ 480 VAC)
- Built-In real-time clock for time and date stamping events along with timer functions for starting, stopping and speed changes without the need for external controls
- Volt meter, ammeter, kilowatt meter elapsed run time meter and heat sink temperature monitoring functions
- Drive internal PI closed-loop control with selectable engineering units
- Independent PI control for use with external device

### Bypass Features

- Bypass and Drive output contactors
- Standard configuration is a lockable main input disconnect switch and requires external branch circuit protection
- Adjustable electronic motor overload protection
- 115 VAC control transformer, fused
- Drive HOA keypad used for bypass control
- Damper control circuit with end of travel feedback and two adjustable wait time functions
- Selectable energy savings mode and harmonic reduction more

- Differential PID feedback feature
- Direct or reverse acting speed signal
- Sleep function in both closed-loop and open-loop control
- Feedback signal loss detection and selectable response strategy
- Feedback signal inverse and square root capability
- 24 VDC, 150 mA power supply
- Input and output terminal status indication
- VFD efficiency: 98% at full-speed; 96% at half-speed
- Diagnostic fault indication
- S-curve soft start / soft stop capability
- Serial communication loss detection and selectable response strategy
- Serial communication status
- 9 preset speeds
- Built-in BACnet protocol (BTL certified)
  - BACnet Health Monitor feature for setup and troubleshooting
- Modbus/Memobus accessible via RS-422/485 communication, which is standard

- LCD keypad: Hand-Off-Auto functions with a built-in copy feature
- Flash upgradeable firmware
- Customizable monitor display
- Heat sink over temperature speed foldback feature
- Bumpless transfer between Hand and Auto modes
- Emergency Override can be used as a Smoke Purge function
- Fan failure detection and selectable drive action
- Customer Analog Input speed reference for ease of wiring to the Bypass board

### Standards

- UL 508A (Industrial Control Panels)
- BTL Certified
- IBC, ICC-ES AC156
- HCAI (OSHPD), IBC, ICC-ES AC156
  - Seismic certification is for wall mounted units only

### Ease of Use Features

- Programming and firmware upgrade without three-phase main power
- QR code for Yaskawa Drive Cloud registration
- Short circuit current rating (SCCR) on nameplate
- In box mounting templates and startup instructions

### Options

- Circuit Breaker (100 kAIC, additional fuses not required)
- Drive Input Fuses
- Drive Service Switch
- 3-Contactor Bypass Switch
- Custom Nameplate
- BACnet/IP
- Ethernet/IP
- LonWorks
- Speed Pot
- Control Transformer (200 VA extra)
- Bluetooth®

## Catalog Code Configuration (H6B2)

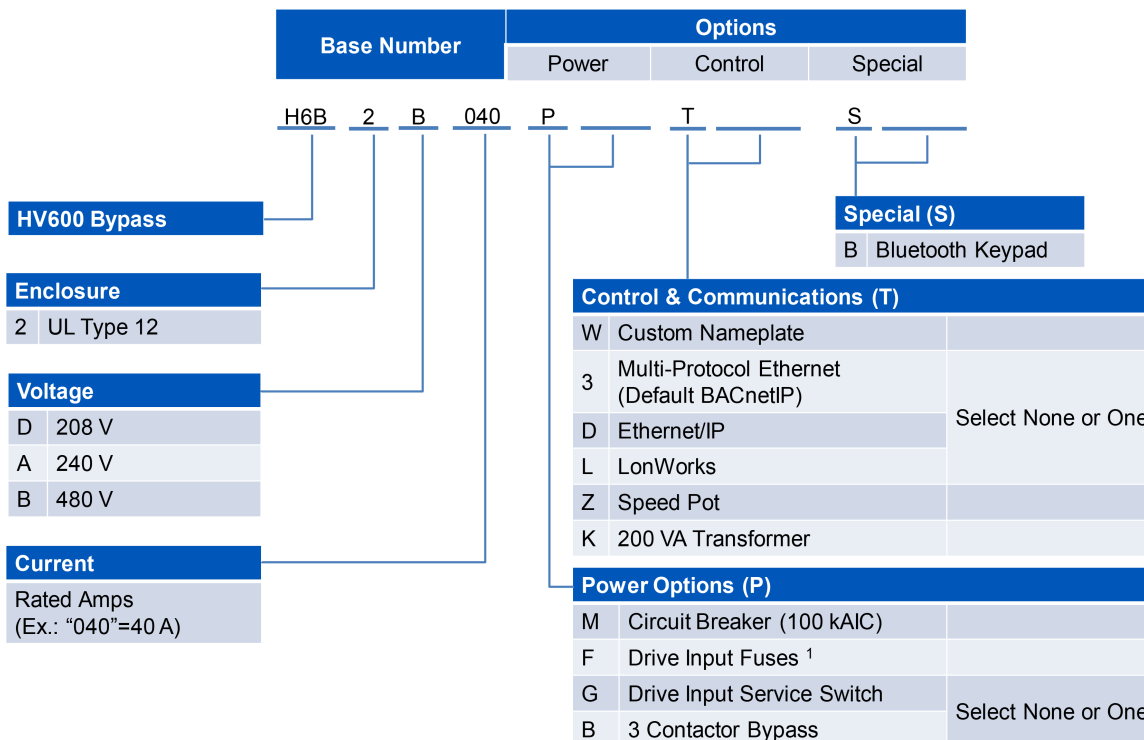

1. For drive input fuses, choose Option F. Option F is not allowed with Option M for the following packages because drive input fusing is automatically included: H6B2D211, H6B2D273, H6B2A192, H6B2A248, H6B2B180, H6B2B240, H6B2B302.

## Package Options (H6B2)

Table 55: Power Options

Option Code	Option	Description
M	Circuit Breaker	Option (M) is a 100 kAIC rated circuit breaker. When option (M) is specified, the bypass drive package will be rated at 100 kAIC. <sup>1</sup>
F	Input Fuses	This option (F) provides input fuses for drive short circuit protection. <sup>2</sup>
B	Drive Input Options	The standard configuration does not include a disconnecting means specifically for the drive. For a 3-contactor bypass that removes power from the drive, select option (B). Or, for a drive input service switch that removes power from the drive, select option (G).
G		

1. When option (M) is not selected, external branch circuit protection is required to achieve desired panel short circuit current rating (kAIC) and is supplied by the customer.
2. Drive input fuses provide short circuit current protection (100kAIC) for the drive and allows for a wider range of external branch circuit protection options supplied by the customer.

## Model Selection

Table 56: 208 V Models and Power Options

Rated Input Voltage	Rated Output Current (Amps)	Nominal HP <sup>1</sup>	UL Type 12 Bypass	Power Options			
				Circuit Breaker (100 kAIC)	Input Fuses	3 - Contactor Bypass	Drive Input Service Switch
			H6B2. . . .	M	F	B	G
208 V 3-Phase	2.4	0.5	D002				
	3.5	0.75	D003				
	4.6	1	D004				
	7.5	2	D007				
	10.6	3	D010				
	16.7	5	D016				
	24.2	7.5	D024				
	30.8	10	D030				
	46.2	15	D046				
	59.4	20	D059				
	74.8	25	D074				
	88	30	D088				
	114	40	D114				
	143	50	D143				
	169	60	D169				
211	75	D211					
273	100	D273					

1. Horsepower rating is based on standard NEMA B, 4-pole motor design as represented in NEC table 430.150 Full-Load Current, Three-Phase Alternating Current Motors at 208 volts.

Table 57: 240 V Models and Power Options

Rated Input Voltage	Rated Output Current (Amps)	Nominal HP <sup>1</sup>	UL Type 12 Bypass	Power Options			
				Circuit Breaker (100 kAIC)	Input Fuses	3 - Contactor Bypass	Drive Input Service Switch
			H6B2. . . .	M	F	B	G
240 V 3-Phase	2.2	0.5	A002				
	3.2	0.75	A003				
	4.2	1	A004				
	6.8	2	A006				
	9.6	3	A009				
	15.2	5	A015				
	22	7.5	A022				
	28	10	A028				
	42	15	A042				
	54	20	A054				
	68	25	A068				
	80	30	A080				
	104	40	A104				
	130	50	A130				
	154	60	A154				
	192	75	A192				
248	100	A248					

1. Horsepower rating is based on standard NEMA B, 4-pole motor design as represented in NEC table 430.150 Full-Load Current, Three-Phase Alternating Current Motors at 240 volts.

Table 58: 480 V Models and Power Options

Rated Input Voltage	Rated Output Current (Amps)	Nominal HP <sup>1</sup>	UL Type 12 Bypass	Power Options			
				Circuit Breaker (100 kAIC)	Input Fuses	3 - Contactor Bypass	Drive Input Service Switch
			H6B2. . . .	M	F	B	G
480 V 3-Phase	1.6	0.5 & 0.75	B001				
	2.1	1	B002				
	3.2	2	B003				
	4.8	3	B004				
	7.6	5	B007				
	11	7.5	B011				
	14	10	B014				
	21	15	B021				
	27	20	B027				
	34	25	B034				
	40	30	B040				
	52	40	B052				
	65	50	B065				
	77	60	B077				
	96	75	B096				
	124	100	B124				
	156	125	B156				
180	150	B180					
240	200	B240					
302	250	B302					

1. Horsepower rating is based on standard NEMA B, 4-pole motor design as represented in NEC table 430.150 Full-Load Current, Three-Phase Alternating Current Motors at 480 volts.

Table 59: Control Options

Option Code	Option	Description
W	Customer Nameplate	Custom engraved nameplates with white lettering on black lamicaid are available with option (W), for special tagging purposes (Example: AHU#1). Note that this option requires the text to be specified by the customer.
3	BACnet/IP Dual Port (Multi-Protocol Ethernet Card)	Multi-Protocol Ethernet Card: BACnet/IP is the default setting.
D	EtherNet/IP Dual Port (SI-EN3D)	ODVA compliant option card to connect to EtherNet/IP.
L	LonWorks (SI-W3)	LonWorks option (L), requires the addition of an optional board.
Z	Speed Pot	This option provides a door-mounted Speed Pot with knob to control motor speed.
K	200 VA Transformer	200 VA Control Power Transformer (for customer use).
B	Bluetooth® Keypad	The Bluetooth® Enabled Keypad provides a wireless connection to your smartphone or tablet.

## Dimensions and Data (H6B2)

Table 60: 208 V UL Type 12

Rated Input Voltage	H6B Bypass Base No. H6B2....	Rated Output Current (Amps)	Nominal HP	Bypass Box No.	Submittal Documents (Outline Drawing) (Schematic) (Submittal Guide)	Drive Part No HV60U. . . .	Enclosed, UL Type 12 Bypass Data			
							Overall Dimensions (in)			Weight (lb)
							H	W	D	
208 V 3-Phase	D002	2.4	0.5	W0	DD.HWF.12.W0.01 DS.H6B2.01 SG.H6B2.10	2011CFA	27.1	18.3	18.8	104
	D003	3.5	0.75			2011CFA				
	D004	4.6	1			2011CFA				
	D007	7.5	2			2011CFA				
	D010	10.6	3			2011CFA				
	D016	16.7	5			2017CFA				
	D024	24.2	7.5	W1	DD.HWF.12.W1.01 DS.H6B2.01 SG.H6B2.10	2024CFA	34.1	19.3	18.9	137
	D030	30.8	10			2031CFA				141
	D046	46.2	15	W2	DD.HWF.12.W2.01 DS.H6B2.01 SG.H6B2.10	2046CFA	37.3	24.5	19.0	189
	D059	59.4	20			2059CFA				193
	D074	74.8	25	W3	DD.HWF.12.W3.01 DS.H6B2.01 SG.H6B2.10	2075CFA	43.6	26.3	21.4	266
	D088	88	30			2088CFA				272
	D114	114	40			2114CFA				285
	D143	143	50	W4	DD.HWF.12.W4.01 DS.H6B2.01 SG.H6B2.10	2143CFA	55.0	33.3	26.3	486
	D169	169	60			2169CFA				502
	D211	211	75	F1 <sup>1</sup>	DD.HWF.12.F1.01 DS.H6B2.01 SG.H6B2.10	2211CBA	85.4	41.3	34.4	853
D273	273	100	2273CBA			867				

1. Floor-mount enclosures are not seismic certified.

Table 61: 240 V UL Type 12

Rated Input Voltage	H6B Bypass Base No. H6B2....	Rated Output Current (Amps)	Nominal HP	Bypass Box No.	Submittal Documents (Outline Drawing) (Schematic) (Submittal Guide)	Drive Part No HV60U. . . .	Enclosed, UL Type 12 Bypass Data			
							Overall Dimensions (in)			Weight (lb)
							H	W	D	
240 V 3-Phase	A002	2.2	0.5	W0	DD.HWF.12.W0.01 DS.H6B2.01 SG.H6B2.10	2011CFA	27.1	18.3	18.8	104
	A003	3.2	0.75			2011CFA				
	A004	4.2	1			2011CFA				
	A006	6.8	2			2011CFA				
	A009	9.6	3			2011CFA				
	A015	15.2	5			2017CFA				
	A022	22	7.5	W1	DD.HWF.12.W1.01 DS.H6B2.01 SG.H6B2.10	2024CFA	34.1	19.3	18.9	131
	A028	28	10			2031CFA				134
	A042	42	15	W2	DD.HWF.12.W2.01 DS.H6B2.01 SG.H6B2.10	2046CFA	37.3	24.5	19.0	184
	A054	54	20			2059CFA				187
	A068	68	25	W3	DD.HWF.12.W3.01 DS.H6B2.01 SG.H6B2.10	2075CFA	43.6	26.3	21.4	261
	A080	80	30			2088CFA				279
	A104	104	40			2114CFA				478
	A130	130	50	W4	DD.HWF.12.W4.01 DS.H6B2.01 SG.H6B2.10	2143CFA	55.0	33.3	26.3	497
	A154	154	60			2169CFA				831
	A192	192	75	F1 <sup>1</sup>	DD.HWF.12.F1.01 DS.H6B2.01 SG.H6B2.10	2211CBA	85.4	41.3	34.4	867
A248	248	100	2273CBA							

1. Floor-mount enclosures are not seismic certified.



Table 62: 480 V UL Type 12

Rated Input Voltage	H6B Bypass Base No. H6B2....	Rated Output Current (Amps)	Nominal HP	Bypass Box No.	Submittal Documents (Outline Drawing) (Schematic) (Submittal Guide)	Drive Part No HV60U. . . .	Enclosed, UL Type 12 Bypass Data			
							Overall Dimensions (in)			Weight (lb)
							H	W	D	
480 V 3-Phase	B1P1	1.1	0.5	W0	DD.HWF.12.W0.01 DS.H6B2.01 SG.H6B2.10	4005CFA	27.1	18.3	18.8	106
	B001	1.6	0.75			4005CFA				
	B002	2.1	1			4005CFA				
	B003	3.4	2			4005CFA				
	B004	4.8	3			4005CFA				
	B007	7.6	5			4008CFA				
	B011	11	7.5			4011CFA				
	B014	14	10			4014CFA				
	B021	21	15	W1	DD.HWF.12.W1.01 DS.H6B2.01 SG.H6B2.10	4021CFA	34.1	19.3	18.9	139
	B027	27	20			4027CFA				142
	B034	34	25			4034CFA				153
	B040	40	30	W2	DD.HWF.12.W2.01 DS.H6B2.01 SG.H6B2.10	4040CFA	37.3	24.5	19.0	190
	B052	52	40			4052CFA				196
	B065	65	50			4065CFA				207
	B077	77	60	W3	DD.HWF.12.W3.01 DS.H6B2.01 SG.H6B2.10	4077CFA	43.6	26.3	21.4	279
	B096	96	75			4096CFA				290
	B124	124	100			4124CFA				301
	B156	156	125	W4	DD.HWF.12.W4.01 DS.H6B2.01 SG.H6B2.10	4156CFA	55.0	33.3	26.3	503
	B180	180	150	F1 <sup>1</sup>	DD.HWF.12.F1.01 DS.H6B2.01 SG.H6B2.10	4180CBA	85.4	41.3	34.4	833
	B240	240	200			4240CBA				865
B302	302	250	4302CBA			953				

1. Floor-mount enclosures are not seismic certified.

## Enclosed Bypass, UL Type 3R (H6B3)



Enclosed Bypass features the HV600 drive and all bypass components housed in a UL Type 3R certified enclosure.

Every HV600 comes with HVAC application-specific software presets, a Hand-Off-Auto LCD keypad, a high-visibility Status Ring for quick visual indication of drive status, and a real-time clock for system accuracy. Popular building automation communication protocols BACnet, Siemens APOGEE, Johnson Controls Metasys, and MEMOBUS/Modbus are embedded in the drive. Interface cards for LonWorks, BACnet/IP, and EtherNet/IP communications are offered separately.

Program the drive prior to installation and upgrade firmware without the need for three-phase main power. Use the free Yaskawa Drive Cloud with the DriveWizard Mobile Application for parameter backups and wired programming with an Android smart device.

### Performance Features

- VT Ratings:
  - 0.5 to 100 HP, 208 VAC
  - 0.5 to 100 HP, 240 VAC
  - 0.5 to 250 HP, 480 VAC
- Overload capacity: 110% for 60 seconds (150% Peak)
- DC Injection braking: at start or stop, adjustable, current limited (anti-windmilling)
- Motor preheat function
- Adjustable Accel/Decel: 0.1 to 6000 seconds
- Controlled speed range: 40:1 (V/f)
- Maximum output frequency: 400 Hz
- Safe Torque Off: SIL3, PLe
- 24 VDC power output to power sensors and other devices (150 mA)
- 24 VDC external power input to maintain network communications and allow for keypad programming and monitoring during a three-phase power loss
- Temperature controlled fans
- Critical frequency rejection capability: 3 selectable, adjustable bands
- Torque limiting: 30 to 180%
- Power loss ride-through: 2 seconds
- Auto restart after power loss or resettable fault, selectable, programmable
- Serial communications loss detection
- Stationary and rotational motor auto-tuning
- 140% starting torque capability, available from 3 Hz to 60 Hz

- Remote speed reference (speed command) signal:
  - 0 to 10 VDC (20 K Ohm)
  - 0 to 20 mA DC (250 Ohm)
  - 4 to 20 mA DC (250 Ohm)
- 8 programmable multi-function input terminals (24 VDC) providing 36+ programmable features, including:
  - Customer safeties
  - BAS / damper interlock
  - Emergency Override
  - Preset speed
  - PID control enable / disable
- 4 programmable multi-function output relays (Form C rated 2 amps @ 250 VAC & 30 VDC), providing 29+ functions, including:
  - Damper control
  - Hand/Auto status
  - Ready/Run/Fault status
  - Overtorque/Undertorque detection

- No load detection (loss of load) fully monitored in drive and bypass modes.

### Service Conditions

- Input voltage:
  - 208 VAC, 240 VAC, 480 VAC, -15/+10%
- Input frequency: 50/60 Hz ±5%
- Ambient service temperature:
  - -10 °C to 40 °C (14 °F to 104 °F)
- Ambient storage temperature: -20 °C to 70 °C (-4 °F to 158 °F)
- Humidity: 0% to 95% non-condensing

### Design Features

- Built in 5% line impedance (0.5 - 100 HP @ 208 VAC, 0.5 - 100 HP @ 240 VAC, 0.75 - 250 HP @ 480 VAC)
- Displacement power factor of 0.98 throughout the motor speed range
- NEC rated input / output amps
- Internal EMI/RFI filter complies with IEC 61800-3 restricted distribution for first environment (Category 2)(0.5 - 100 HP @ 208 VAC, 0.5 - 100 HP @ 240 VAC, 0.75 to 250 HP @ 480 VAC)
- Built-In real-time clock for time and date stamping events along with timer functions for starting, stopping and speed changes without the need for external controls
- Volt meter, ammeter, kilowatt meter elapsed run time meter and heat sink temperature monitoring functions
- Drive internal PI closed-loop control with selectable engineering units
- Independent PI control for use with external device

### Bypass Features

- Bypass and Drive output contactors
- Standard configuration is a lockable main input disconnect switch and requires external branch circuit protection
- Adjustable electronic motor overload protection
- 115 VAC control transformer, fused
- Drive HOA keypad used for bypass control
- Damper control circuit with end of travel feedback and two adjustable wait time functions
- Selectable energy savings mode and harmonic reduction more

- Differential PID feedback feature
- Direct or reverse acting speed signal
- Sleep function in both closed-loop and open-loop control
- Feedback signal loss detection and selectable response strategy
- Feedback signal inverse and square root capability
- 24 VDC, 150 mA power supply
- Input and output terminal status indication
- VFD efficiency: 98% at full-speed; 96% at half-speed
- Diagnostic fault indication
- S-curve soft start / soft stop capability
- Serial communication loss detection and selectable response strategy
- Serial communication status
- 9 preset speeds
- Built-in BACnet protocol (BTL certified)
  - BACnet Health Monitor feature for setup and troubleshooting
- Modbus/Memobus accessible via RS-422/485 communication, which is standard

- LCD keypad: Hand-Off-Auto functions with a built-in copy feature
- Flash upgradeable firmware
- Customizable monitor display
- Heat sink over temperature speed foldback feature
- Bumpless transfer between Hand and Auto modes
- Emergency override can be used as a Smoke Purge function
- Fan failure detection and selectable drive action
- Customer Analog Input speed reference for ease of wiring to the Bypass board

- QR code for Yaskawa Drive Cloud registration
- Short circuit current rating (SCCR) on nameplate
- In box mounting templates and startup instructions

**Options**

- Circuit Breaker (100 kAIC, additional fuses not required)
- 3-Contactor Bypass
- Drive Service Switch
- Drive Input Fuses
- Space Heater
- Custom Nameplate
- BACnet/IP
- Ethernet/IP
- LonWorks
- Control Transformer (200 VA extra)
- Keypad Viewing Window
- Speed Pot
- Bluetooth®

**Standards**

- UL 508A (Industrial Control Panels)
- BTL Certified
- IBC, ICC-ES AC156
- HCAI (OSHPD), IBC, ICC-ES AC156
  - Seismic certification is for wall mounted units only

**Ease of Use Features**

- Programming and firmware upgrade without three-phase main power

# Catalog Code Configuration (H6B3)

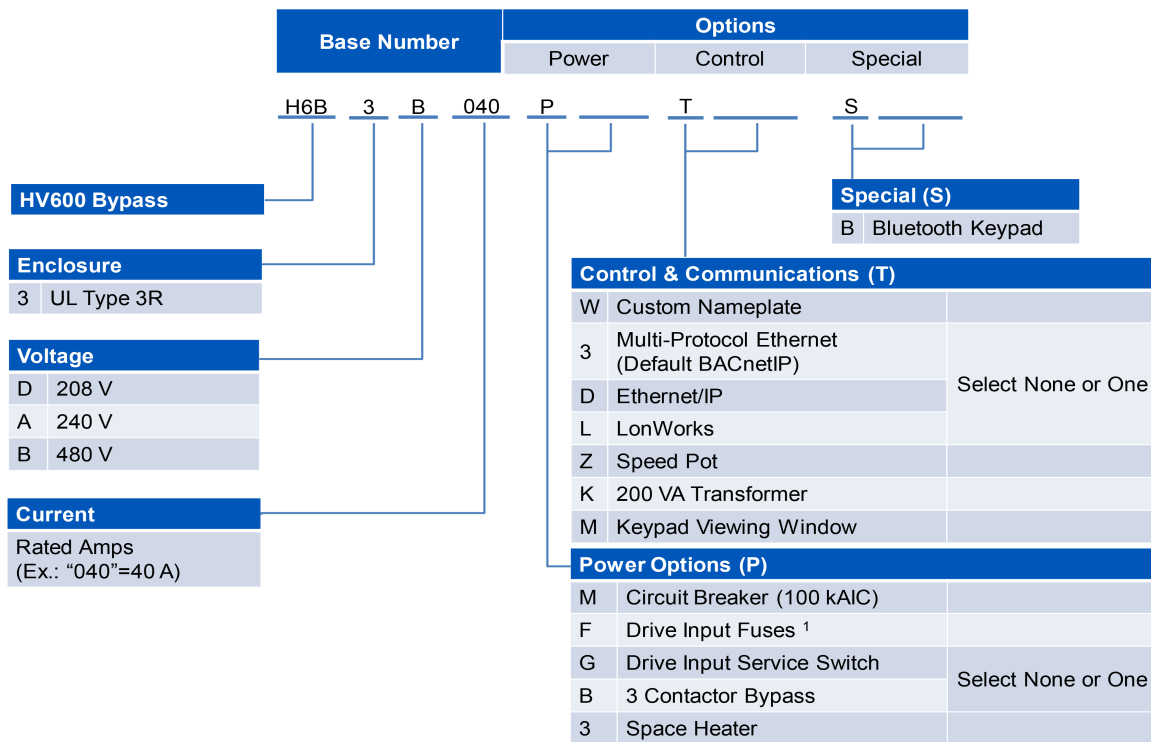

1. UL Type 3R Packages using the Option (M) do not require drive input fusing to achieve 100 kAIC rating.

## Package Options (H6B3)

**Table 63: Freestanding Leg Kit UL Type 3R**

Leg Kit: This option allows the UL Type 3R wall-mount enclosures to be mounted on legs (18 or 30 inch height) so that the control can be freestanding and off the ground. Kits are purchased separate and shipped loose for field installation. Floor-mount enclosures come standard with freestanding legs.

Enclosure Size	Leg Height (in)	Part Number
W1	18	UUX002073
W2	18	UUX002078
W3	18	UUX002079
W4	18	UUX002080
W1	30	UUX002081
W2	30	UUX002082
W3	30	UUX002083
W4	30	UUX002084

**Table 64: Power Options**

Option Code	Option	Description
M	Circuit Breaker	Option (M) is a 100 kAIC rated circuit breaker. When option (M) is specified, the bypass drive package will be rated at 100 kAIC. <sup>1</sup>
F	Input Fuses	This option (F) provides input fuses for drive short circuit protection. <sup>2</sup>
B	Drive Input Options	The standard configuration does not include a disconnecting means specifically for the drive. For a 3-contactor bypass that removes power from the drive, select option (B). Or, for a drive input service switch that removes power from the drive, select option (G).
G		
3	Space Heater	This option helps reduce condensation.

1. When option (M) is not selected, external branch circuit protection is required to achieve desired panel short circuit current rating (kAIC) and is supplied by the customer.
2. Drive input fuses provide short circuit current protection (100kAIC) for the drive and allows for a wider range of external branch circuit protection options supplied by the customer.

## Model Selection

Table 65: 208 V Models and Power Options

Rated Input Voltage	Rated Output Current (Amps)	Nominal HP <sup>1</sup>	UL Type 3R Bypass	Power Options				
			H6B3 . . .	Circuit Breaker (100 kAIC)	Input Fuses	3 - Contactor Bypass	Drive Input Service Switch	Space Heater
				M	F	B	G	3
208 V 3-Phase	2.4	0.5	D002					
	3.5	0.75	D003					
	4.6	1	D004					
	7.5	2	D007					
	10.6	3	D010					
	16.7	5	D016					
	24.2	7.5	D024					
	30.8	10	D030					
	46.2	15	D046					
	59.4	20	D059					
	74.8	25	D074					
	88	30	D088					
	114	40	D114					
	143	50	D143					
	169	60	D169					
211	75	D211						
273	100	D273						

1. Horsepower rating is based on standard NEMA B, 4-pole motor design as represented in NEC table 430.150 Full-Load Current, Three-Phase Alternating Current Motors at 208 volts.

Table 66: 240 V Models and Power Options

Rated Input Voltage	Rated Output Current (Amps)	Nominal HP <sup>1</sup>	UL Type 3R Bypass	Power Options				
				Circuit Breaker (100 kAIC)	Input Fuses	3 - Contactor Bypass	Drive Input Service Switch	Space Heater
			H6B3. . . .	M	F	B	G	3
240 V 3-Phase	2.2	0.5	A002					
	3.2	0.75	A003					
	4.2	1	A004					
	6.8	2	A006					
	9.6	3	A009					
	15.2	5	A015					
	22	7.5	A022					
	28	10	A028					
	42	15	A042					
	54	20	A054					
	68	25	A068					
	80	30	A080					
	104	40	A104					
	130	50	A130					
	154	60	A154					
	192	75	A192					
248	100	A248						

1. Horsepower rating is based on standard NEMA B, 4-pole motor design as represented in NEC table 430.150 Full-Load Current, Three-Phase Alternating Current Motors at 240 volts.

Table 67: 480 V Models and Power Options

Rated Input Voltage	Rated Output Current (Amps)	Nominal HP <sup>1</sup>	UL Type 3R Bypass	Power Options				
				Circuit Breaker (100 kAIC)	Input Fuses	3 - Contactor Bypass	Drive Input Service Switch	Space Heater
			H6B3. . . .	M	F	B	G	3
480 V 3-Phase	1.6	0.5 & 0.75	B001					
	2.1	1	B002					
	3.4	2	B003					
	4.8	3	B004					
	7.6	5	B007					
	11	7.5	B011					
	14	10	B014					
	21	15	B021					
	27	20	B027					
	34	25	B034					
	40	30	B040					
	52	40	B052					
	65	50	B065					
	77	60	B077					
	96	75	B096					
	124	100	B124					
	156	125	B156					
180	150	B180						
240	200	B240						
302	250	B302						

1. Horsepower rating is based on standard NEMA B, 4-pole motor design as represented in NEC table 430.150 Full-Load Current, Three-Phase Alternating Current Motors at 480 volts.

Table 68: Control Options

Option Code	Option	Description
W	Customer Nameplate	Custom engraved nameplates with white lettering on black lamicaid are available with option (W), for special tagging purposes (Example: AHU#1). Note that this option requires the text to be specified by the customer.
3	BACnet/IP Dual Port (Multi-Protocol Ethernet Card)	Multi-Protocol Ethernet Card: BACnet/IP is the default setting.
D	EtherNet/IP Dual Port (SI-EN3D)	ODVA compliant option card to connect to EtherNet/IP.
L	LonWorks (SI-W3)	LonWorks option (L), requires the addition of an optional board.
Z	Speed Pot	This option provides a door-mounted Speed Pot with knob to control motor speed.
K	200 VA Transformer	200 VA Control Power Transformer (for customer use).
M	Keypad Viewing Window	The digital drive keypad is mounted on the outside of the UL Type 3R enclosure door. This option provides a viewing window that is hinged and lockable.
B	Bluetooth® Keypad	The Bluetooth® Enabled Keypad provides a wireless connection to your smartphone or tablet.

## Dimensions and Data (H6B3)

Table 69: 208 V UL Type 3R

Rated Input Voltage	HV600 Bypass Base No. H6B3....	Rated Output Current (Amps)	Nominal HP	Bypass Box No.	Submittal Documents (Outline Drawing) (Schematic) (Submittal Guide)	Drive Part No HV60U	Enclosed, UL Type 3R Bypass Data			
							Overall Dimensions (in)			Weight (lb)
							H	W	D	
208 V 3-Phase	D002	2.4	0.5	W1	DD.HWF.3R.W1.01 DS.H6B3.01 SG.H6B3.10	2011CFA	39.2	18.6	18.1	150
	D003	3.5	0.75			2011CFA				
	D004	4.6	1			2011CFA				
	D007	7.5	2			2011CFA				
	D010	10.6	3			2011CFA				
	D016	16.7	5			2017CFA				
	D024	24.2	7.5			2024CFA				
	D030	30.8	10			2031CFA				
	D046	46.2	15	W2	DD.HWF.3R.W2.01 DS.H6B3.01 SG.H6B3.10	2046CFA	44.2	20.6	20.1	176
	D059	59.4	20			2059CFA				182
	D074	74.8	25	W3	DD.HWF.3R.W3.01 DS.H6B3.01 SG.H6B3.10	2075CFA	49.2	26.6	22.1	284
	D088	88	30			2088CFA				289
	D114	114	40			2114CFA				300
	D143	143	50	W4	DD.HWF.3R.W4.01 DS.H6B3.01 SG.H6B3.10	2143CFA	61.2	38.6	25.1	554
	D169	169	60			2169CFA				567
	D211	211	75	F1 <sup>1</sup>	DD.HWF.3R.F1.01 DS.H6B3.01 SG.H6B3.10	2211CBA	93.5	43.6	48.6	1,039
D273	273	100	2273CBA			1,054				

1. Floor-mount enclosures are not seismic certified.



Table 70: 240 V UL Type 3R

Rated Input Voltage	HV600 Bypass Base No. H6B3....	Rated Output Current (Amps)	Nominal HP	Bypass Box No.	Submittal Documents (Outline Drawing) (Schematic) (Submittal Guide)	Drive Part No HV60U	Enclosed, UL Type 3R Bypass Data			
							Overall Dimensions (in)			Weight (lb)
							H	W	D	
240 V 3-Phase	A002	2.2	0.5	W1	DD.HWF.3R.W1.01 DS.H6B3.01 SG.H6B3.10	2011CFA	39.2	18.6	18.1	150
	A003	3.2	0.75			2011CFA				
	A004	4.2	1			2011CFA				
	A006	6.8	2			2011CFA				
	A009	9.6	3			2011CFA				
	A015	15.2	5			2017CFA				
	A022	22	7.5			2024CFA				
	A028	28	10			2031CFA				
	A042	42	15	W2	DD.HWF.3R.W2.01 DS.H6B3.01 SG.H6B3.10	2046CFA	44.2	20.6	20.1	176
	A054	54	20			2059CFA				181
	A068	68	25	W3	DD.HWF.3R.W3.01 DS.H6B3.01 SG.H6B3.10	2075CFA	49.2	26.6	22.1	285
	A080	80	30			2088CFA				304
	A104	104	40			2114CFA				545
	A130	130	50	W4	DD.HWF.3R.W4.01 DS.H6B3.01 SG.H6B3.10	2143CFA	61.2	38.6	25.1	563
	A154	154	60			2169CFA				1,019
	A192	192	75	F1 <sup>1</sup>	DD.HWF.3R.F1.01 DS.H6B3.01 SG.H6B3.10	2211CBA	93.5	43.6	48.6	1,055
A248	248	100	2273CBA							

1. Floor-mount enclosures are not seismic certified.

Table 71: 480 V UL Type 3R

Rated Input Voltage	HV600 Bypass Base No. H6B3....	Rated Output Current (Amps)	Nominal HP	Bypass Box No.	Submittal Documents (Outline Drawing) (Schematic) (Submittal Guide)	Drive Part No HV60U	Enclosed, UL Type 3R Bypass Data			
							Overall Dimensions (in)			Weight (lb)
							H	W	D	
480 V 3-Phase	B1P1	1.1	0.5	W1	DD.HWF.3R.W1.01 DS.H6B3.01 SG.H6B3.10	4005CFA	39.2	18.6	18.2	152
	B001	1.6	0.75							
	B002	2.1	1							
	B003	3.4	2							
	B004	4.8	3							
	B007	7.6	5							
	B011	11	7.5							
	B014	14	10							
	B021	21	15							
	B027	27	20							
	B034	34	25	W2	DD.HWF.3R.W2.01 DS.H6B3.01 SG.H6B3.10	4034CFA	44.2	20.6	20.1	164
	B040	40	30			4040CFA				178
	B052	52	40			4052CFA				185
	B065	65	50	W3	DD.HWF.3R.W3.01 DS.H6B3.01 SG.H6B3.10	4065CFA	49.2	26.6	22.1	200
	B077	77	60			4077CFA				290
	B096	96	75			4096CFA				307
	B124	124	100	W4	DD.HWF.3R.W4.01 DS.H6B3.01 SG.H6B3.10	4124CFA	61.2	38.6	25.1	320
	B156	156	125			4156CFA				567
	B180	180	150			F1 <sup>1</sup>				DD.HWF.3R.F1.01 DS.H6B3.01 SG.H6B3.10
	B240	240	200	4240CBA	1,057					
B302	302	250	4302CBA	1,163						

1. Floor-mount enclosures are not seismic certified.

# Narrow Configured, UL Type 1 (H6CP)



The HV600 Narrow Configured package provides a HV600 above a UL Type 1 enclosure that houses an input disconnect switch and space for several commonly used option, such as fuses, circuit breakers, etc. The HV600 Narrow Configured has been designed for flexibility in providing the features and options commonly specified by facility designers. The enclosure design is narrow, which conserves control room wall space.

The HV600 Drive is a variable torque AC drive, designed specifically for HVAC applications in building automation. A new benchmark for size, cost, performance, benefits, and quality, the HV600 includes numerous built-in features such as Network Communications, H/O/A, PI control, and energy-savings functions.

The HV600 has embedded communications for the popular building automation protocols BACnet, Modbus, Siemens APOGEE, and Johnson Controls Metasys. Optional LonWorks, BACnet/IP, or EtherNet/IP interface cards are also available.

Program the drive prior to installation and upgrade firmware without the need for three-phase main power. Use the free Yaskawa Drive Cloud with the DriveWizard Mobile Application for parameter backups and wired programming with an Android smart device.

## Performance Features

- VT Ratings:
  - 0.5 to 40 HP, 208 VAC
  - 0.75 to 75 HP, 480 VAC
- Overload capacity: 110% for 60 seconds (150% Peak)
- DC Injection braking: at start or stop, adjustable, current limited (anti-windmilling)
- Adjustable Accel/Decel: 0.1 to 6000 seconds
- Controlled speed range: 40:1 (V/f)
- Critical frequency rejection capability: 3 selectable, adjustable bands
- Power loss ride-through: 2 seconds
- Torque limiting: 30 to 180%
- Auto restart after power loss or resettable fault, selectable, programmable
- Serial communications loss detection
- Up/down speed control (MOP)
- Stationary motor auto-tuning
- 140% starting torque capability, available from 3 Hz to 60 Hz
- Remote speed reference (speed command) signal:
  - 0 to 10 VDC (20 K Ohm)
  - 4 to 20 mA DC (250 Ohm)
- 7 programmable multi-function input terminals (24 VDC) providing 60+ programmable features, including:
  - Customer safeties
  - BAS / damper interlock
  - Emergency Override
  - Preset speed

- PID control enable / disable

- 3 programmable multi-function output relays (Form A rated 2 amps @ 250 VAC & 30 VDC), providing 50+ functions, including:
  - Damper control
  - Hand/Auto status
  - Contactor control for external bypass
  - Overtorque/Undertorque detection
- One fixed, Fault, form C output relay (Rated 2 amps @250 VAC & 30 VDC)
- 2 Functional Safety Inputs

## Service Conditions

- Input voltage:
  - 208 VAC, 480 VAC, -15/+10%
- Input frequency: 50/60 Hz  $\pm$ 5%
- Ambient service temperature:
  - -10 °C to 40°C (14 °F to 104 °F)
- Ambient storage temperature: -20°C to 70°C (-4 °F to 158 °F)
- Humidity: 0% to 95% non-condensing
- Service factor: 1.0

## Design Features

- Standard configuration is a lockable main input disconnect switch and requires external branch circuit protection
- Adjustable electronic motor overload protection
- Built in 5% line impedance
- Displacement power factor of 0.98 throughout the motor speed range

- NEC rated input / output amps
- Internal EMI/RFI filter complies with IEC 61800-3 restricted distribution for first environment
- Built-In real-time clock for time and date stamping events along with timer functions for starting, stopping and speed changes without the need for external controls
- Volt meter, ammeter, kilowatt meter elapsed run time meter and heat sink temperature monitoring functions
- Drive internal PI closed-loop control with selectable engineering units
- Independent PI control for use with external device
- Differential PID feedback feature
- Sleep function in both closed-loop and open-loop control
- Feedback signal low pass filter
- Feedback signal loss detection and selectable response strategy
- Feedback signal inverse and square root capability
- 24 VDC, 150 mA power supply
- Input and output terminal status indication
- VFD efficiency: 98% at full-speed; 96% at half-speed
- Diagnostic fault indication
- S-curve soft start / soft stop capability
- Serial communication loss detection and selectable response strategy
- Serial communication status
- No load detection (broken belt alert)

- 7 preset speeds
- Built-in BACnet protocol (BTL certified)
  - BACnet Health Monitor feature for setup and troubleshooting
- Modbus/Memobus accessible via RS-422/485 communication standard
- Kinetic Energy Braking (KEB) function maintains the DC bus voltage during a power-loss by using kinetic energy from the motor
- LCD keypad: Hand-Off-Auto functions with a built-in copy feature
- Motor preheat function
- Flash upgradeable firmware
- Customizable monitor display
- Heat sink over temperature speed foldback feature

- Bumpless transfer between Hand and Auto modes
- Emergency override can be used as a Smoke Purge function
- Fan failure detection and selectable drive action

### Ease of Use Features

- LED Status Ring for clear drive operational status
- Programming and firmware upgrade without three-phase main power
- QR code for Yaskawa Drive Cloud registration
- Short circuit current rating (SCCR) on nameplate
- In box mounting templates and startup instructions

### Standards

- UL 508A (Industrial Control Panels)
- BTL listed
- HCAI (OSHDP), IBC, ICC-ES AC156
  - Seismic certification is for wall mounted units only

### Options

- Circuit Breaker (100 kAIC)
- Input Fuses
- Custom Nameplate
- BACnet/IP
- Ethernet/IP
- LonWorks
- Bluetooth®

## Catalog Code Configuration (H6CP)

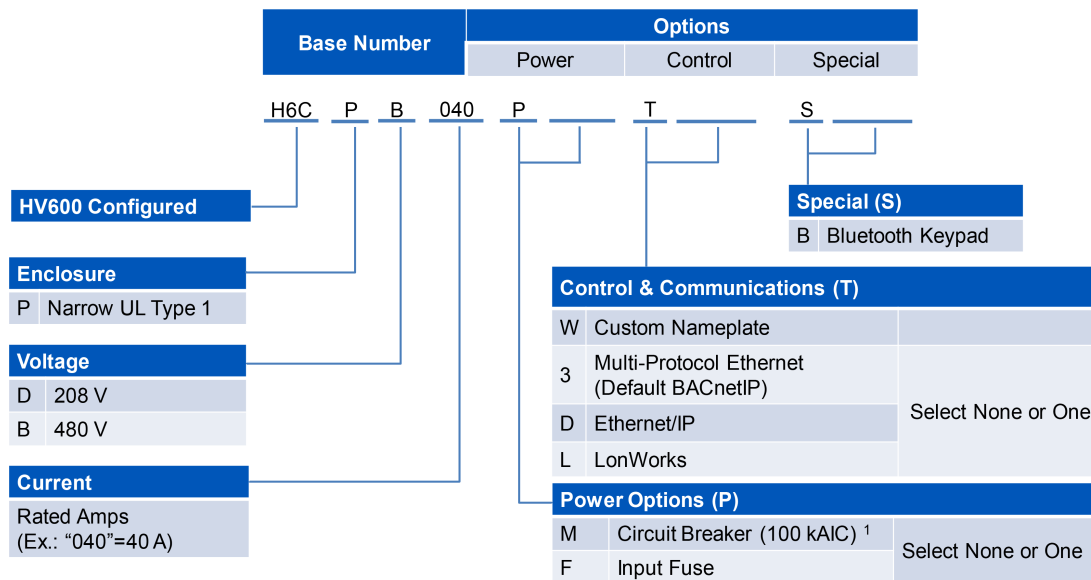

1. Drive input fuses are included in all Narrow Configured packages with the PM (Circuit Breaker) option.

## Package Options (H6CP)

Table 72: Power Options

Option Code	Option	Description
M	Circuit Breaker	Option (M) is a 100 kAIC rated circuit breaker with fuses. When option (M) is specified, the configured drive package will be rated at 100 kAIC. <sup>1</sup>
F	Input Fuses	This option (F) provides drive input fuses for drive short circuit protection. <sup>2</sup>

1. When option (M) is not selected, external branch circuit protection is required to achieve desired panel short circuit current rating (kAIC) and is supplied by the customer.
2. Drive input fuses provide short circuit current protection (100kAIC) for the drive and allows for a wider range of external branch circuit protection options supplied by the customer.

## Model Selection

Table 73: 0.5 to 40 HP, 208 V 3-phase input, and Power Options

Rated Input Voltage	Rated Output Current (Amps)	Nominal HP <sup>1</sup>	UL Type 1 Configured	Power Options	
				Circuit Breaker (100 kAIC)	Input Fuse
			H6CP . . .	M	F
208 V 3-Phase	2.4	0.5	D002	-	
	3.5	0.75	D003		
	4.6	1	D004		
	7.5	2	D007		
	10.6	3	D010		
	16.7	5	D016		
	24.2	7.5	D024		
	30.8	10	D030		
	46.2	15	D046		
	59.4	20	D059		
	74.8	25	D074		
	88	30	D088		
114	40	D114			

1. Horsepower rating is based on standard NEMA B, 4-pole motor design as represented in NEC table 430.150 Full-Load Current, Three-Phase Alternating Current Motors at 208 volts.

Table 74: 0.75 to 75 HP, 480 V 3-phase input and Power Options

Rated Input Voltage	Rated Output Current (Amps)	Nominal HP <sup>1</sup>	UL Type 1 Configured	Power Options	
				Circuit Breaker (100 kAIC)	Input Fuse
			H6CP . . .	M	F
480 V 3-Phase	1.6	0.75	B001	-	
	2.1	1	B002		
	3.2	2	B003		
	4.8	3	B004		
	7.6	5	B007		
	11	7.5	B011		
	14	10	B014		
	21	15	B021		
	27	20	B027		
	34	25	B034		
	40	30	B040		
	52	40	B052		
	65	50	B065		
	77	60	B077		
	96	75	B096		

1. Horsepower rating is based on standard NEMA B, 4-pole motor design as represented in NEC table 430.150 Full-Load Current, Three-Phase Alternating Current Motors at 480 volts.

Table 75: Control Options

Option Code	Option	Description
W	Customer Nameplate	Custom engraved nameplates with white lettering on black lamicaid are available with option (W), for special tagging purposes, for example, AHU #1. Note that this option requires the text to be specified by the customer.
3	BACnet/IP Dual Port (Multi-Protocol Ethernet Card)	Multi-Protocol Ethernet Card: BACnet/IP is the default setting.
D	EtherNet/IP Dual Port (SI-EN3D)	ODVA compliant option card to connect to EtherNet/IP.
L	LonWorks (SI-W3)	LonWorks, option (L), requires the addition of an optional board.
B	Bluetooth® Keypad	The Bluetooth® Enabled Keypad provides a wireless connection to your smartphone or tablet.

## Dimensions and Data

Table 76: 208 V UL Type 1 Packages

Rated Input Voltage	H6C Configured Base No. H6CP....	Rated Output Current (Amps)	Nominal HP	Configured Box No.	Submittal Documents (Outline Drawing) (Schematic) (Submittal Guide)	Drive Part No. HV60U	Enclosure, UL Type 1			
							Overall Dimensions (in)			Weight (lb)
							H	W	D	
208 V 3-Phase	D002	2.4	0.5	W1	DD.HC.1.W1.01 DS.H6CP.01 SG.H6CP.10	2011CFA	33.0	6.3	13.9	41
	D003	3.5	0.75			2011CFA				
	D004	4.6	1			2011CFA				
	D007	7.5	2			2011CFA				
	D010	10.6	3			2011CFA				
	D016	16.7	5			2017CFA				
	D024	24.2	7.5	W2	DD.HC.1.W2.01 DS.H6CP.01 SG.H6CP.10	2024CFA	36.6			47
	D030	30.8	10			2031CFA				49
	D046	46.2	15	W3	DD.HC.1.W3.01 DS.H6CP.01 SG.H6CP.10	2046CFA	39.9	9.0	14.2	67
	D059	59.4	20			2059CFA				70
	D074	74.8	25	W4	DD.HC.1.W4.01 DS.H6CP.01 SG.H6CP.10	2075CFA	45.8	11.0	15.1	101
	D088	88	30			2088CFA				106
	D114	114	40			2114CFA				114

Table 77: 480 V UL Type 1 Packages

Rated Input Voltage	H6C Configured Base No. H6CP....	Rated Output Current (Amps)	Nominal HP	Configured Box No.	Submittal Documents (Outline Drawing) (Schematic) (Submittal Guide)	Drive Part No. HV60U	Enclosure, UL Type 1			
							Overall Dimensions (in)			Weight (lb)
							H	W	D	
480 V 3-Phase	B001	1.6	0.75	W1	DD.HC.1.W1.01 DS.H6CP.01 SG.H6CP.10	4005CFA	33.0	6.3	13.9	42
	B002	2.1	1			4005CFA				
	B003	3.4	2			4005CFA				
	B004	4.8	3			4005CFA				
	B007	7.6	5			4008CFA				
	B011	11	7.5			4011CFA				
	B014	14	10			4014CFA				
	B021	21	15	W2	DD.HC.1.W2.01 DS.H6CP.01 SG.H6CP.10	4021CFA	36.6	9.0	14.2	48
	B027	27	20			4027CFA				50
	B034	34	25			4034CFA				53
	B040	40	30	W3	DD.HC.1.W3.01 DS.H6CP.01 SG.H6CP.10	4040CFA	39.9	9.0	14.2	70
	B052	52	40			4052CFA				75
	B065	65	50	W4	DD.HC.1.W4.01 DS.H6CP.01 SG.H6CP.10	4065CFA	45.8	11.0	15.1	94
	B077	77	60			4077CFA				108
	B096	96	75			4096CFA				118

## Narrow Configured, UL Type 12 (H6CN)



The HV600 Narrow Configured package provides a HV600 above a UL Type 12 enclosure that houses an input disconnect switch and space for several commonly used option, such as fuses, circuit breakers, etc. The HV600 Narrow Configured has been designed for flexibility in providing the features and options commonly specified by facility designers. The enclosure design is narrow, which conserves control room wall space.

The HV600 Drive is a variable torque AC drive, designed specifically for HVAC applications in building automation. A new benchmark for size, cost, performance, benefits, and quality, the HV600 includes numerous built-in features such as Network Communications, H/O/A, PI control, and energy-savings functions.

The HV600 has embedded communications for the popular building automation protocols BACnet, Modbus, Siemens APOGEE, and Johnson Controls Metasys. Optional LonWorks, BACnet/IP, or EtherNet/IP interface cards are also available.

Program the drive prior to installation and upgrade firmware without the need for three-phase main power. Use the free Yaskawa Drive Cloud with the DriveWizard Mobile Application for parameter backups and wired programming with an Android smart device.

### Performance Features

- VT Ratings:
  - 0.5 to 20 HP, 208 VAC
  - 0.75 to 40HP, 480 VAC
- Overload capacity: 110% for 60 seconds (150% Peak)
- DC Injection braking: at start or stop, adjustable, current limited (anti-windmilling)
- Adjustable Accel/Decel: 0.1 to 6000 seconds
- Controlled speed range: 40:1 (V/f)
- Critical frequency rejection capability: 3 selectable, adjustable bands
- Power loss ride-through: 2 seconds
- Torque limiting: 30 to 180%
- Auto restart after power loss or resettable fault, selectable, programmable
- Serial communications loss detection
- Up/down speed control (MOP)
- Stationary motor auto-tuning
- 140% starting torque capability, available from 3 Hz to 60 Hz
- Remote speed reference (speed command) signal:
  - 0 to 10 VDC (20 K Ohm)
  - 4 to 20 mA DC (250 Ohm)
- 7 programmable multi-function input terminals (24 VDC) providing 60+ programmable features, including:
  - Customer safeties
  - BAS / damper interlock
  - Emergency Override
  - Preset speed

- PID control enable / disable
- 3 programmable multi-function output relays (Form A rated 2 amps @ 250 VAC & 30 VDC), providing 50+ functions, including:
  - Damper control
  - Hand/Auto status
  - Contactor control for external bypass
  - Overtorque/Undertorque detection
- One fixed, Fault, form C output relay (Rated 2 amps @250 VAC & 30 VDC)
- 2 Functional Safety Inputs

### Service Conditions

- Input voltage:
  - 208 VAC, 480 VAC, -15/+10%
- Input frequency: 50/60 Hz ±5%
- Ambient service temperature:
  - -10 °C to 40°C (14 °F to 104 °F)
- Ambient storage temperature: -20°C to 70°C (-4 °F to 158 °F)
- Humidity: 0% to 95% non-condensing
- Service factor: 1.0

### Design Features

- Standard configuration is a lockable main input disconnect switch and requires external branch circuit protection
- Adjustable electronic motor overload protection
- Built in 5% line impedance
- Displacement power factor of 0.98 throughout the motor speed range

- NEC rated input / output amps
- Internal EMI/RFI filter complies with IEC 61800-3 restricted distribution for first environment
- Built-In real-time clock for time and date stamping events along with timer functions for starting, stopping and speed changes without the need for external controls
- Volt meter, ammeter, kilowatt meter elapsed run time meter and heat sink temperature monitoring functions
- Drive internal PI closed-loop control with selectable engineering units
- Independent PI control for use with external device
- Differential PID feedback feature
- Sleep function in both closed-loop and open-loop control
- Feedback signal low pass filter
- Feedback signal loss detection and selectable response strategy
- Feedback signal inverse and square root capability
- 24 VDC, 150 mA power supply
- Input and output terminal status indication
- VFD efficiency: 98% at full-speed; 96% at half-speed
- Diagnostic fault indication
- S-curve soft start / soft stop capability
- Serial communication loss detection and selectable response strategy
- Serial communication status
- No load detection (broken belt alert)



- 7 preset speeds
- Built-in BACnet protocol (BTL certified)
  - BACnet Health Monitor feature for setup and troubleshooting
- Modbus/Memobus accessible via RS-422/485 communication standard
- Kinetic Energy Braking (KEB) function maintains the DC bus voltage during a power-loss by using kinetic energy from the motor
- LCD keypad: Hand-Off-Auto functions with a built-in copy feature
- Motor preheat function
- Flash upgradeable firmware
- Customizable monitor display
- Heat sink over temperature speed foldback feature

- Bumpless transfer between Hand and Auto modes
- Emergency override can be used as a Smoke Purge function
- Fan failure detection and selectable drive action

### Ease of Use Features

- LED Status Ring for clear drive operational status
- Programming and firmware upgrade without three-phase main power
- QR code for Yaskawa Drive Cloud registration
- Short circuit current rating (SCCR) on nameplate
- In box mounting templates and startup instructions

### Standards

- UL 508A (Industrial Control Panels)
- BTL listed

### Options

- Circuit Breaker (100 kAIC)
- Input Fuses
- Custom Nameplate
- BACnet/IP
- Ethernet/IP
- LonWorks
- Bluetooth®

## Catalog Code Configuration (H6CN)

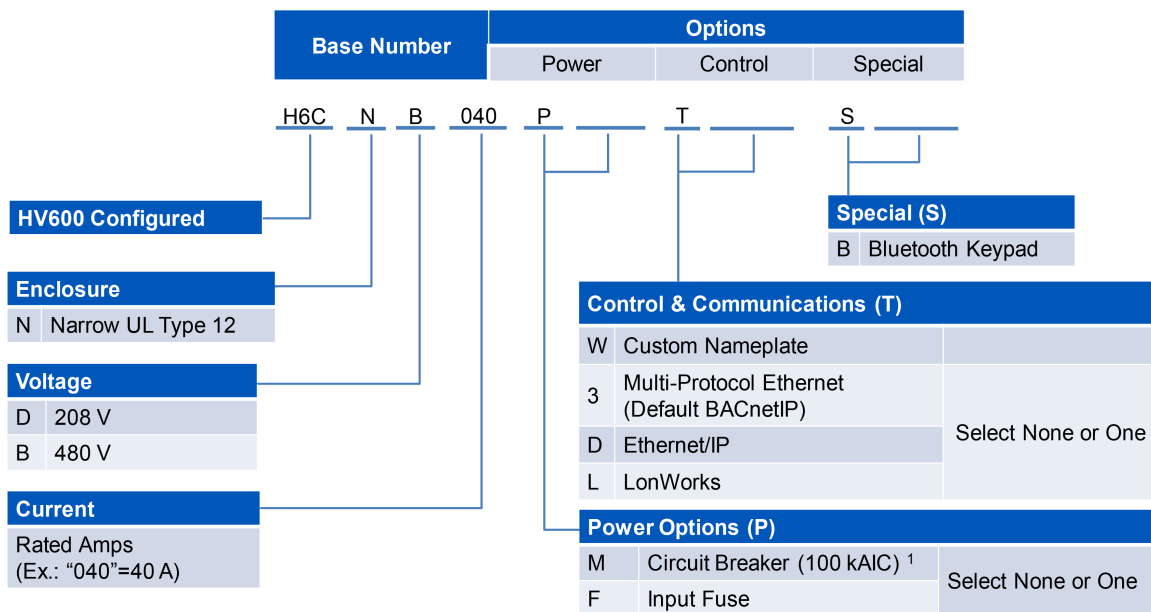

1. Drive input fuses are included in all Narrow Configured packages with the PM (Circuit Breaker) option.

## Package Options (H6CN)

Table 78: Power Options

Option Code	Option	Description
M	Circuit Breaker	Option (M) is a 100 kAIC rated circuit breaker with fuses. When option (M) is specified, the configured drive package will be rated at 100 kAIC. <sup>1</sup>
F	Input Fuses	This option (F) provides drive input fuses for drive short circuit protection. <sup>2</sup>

1. When option (M) is not selected, external branch circuit protection is required to achieve desired panel short circuit current rating (kAIC) and is supplied by the customer.  
 2. Drive input fuses provide short circuit current protection (100kAIC) for the drive and allows for a wider range of external branch circuit protection options supplied by the customer.

## Model Selection

Table 79: 0.5 to 40 HP, 208 V 3-phase input, and Power Options

Rated Input Voltage	Rated Output Current (Amps)	Nominal HP <sup>1</sup>	UL Type 1 Configured	Power Options	
				Circuit Breaker (100 kAIC)	Input Fuse
			H6CP . . .	M	F
208 V 3-Phase	2.4	0.5	D002	-	
	3.5	0.75	D003		
	4.6	1	D004		
	7.5	2	D007		
	10.6	3	D010		
	16.7	5	D016		
	24.2	7.5	D024		
	30.8	10	D030		
	46.2	15	D046		
	59.4	20	D059		
	74.8	25	D074		
	88	30	D088		
114	40	D114			

1. Horsepower rating is based on standard NEMA B, 4-pole motor design as represented in NEC table 430.150 Full-Load Current, Three-Phase Alternating Current Motors at 208 volts.

Table 80: 0.75 to 75 HP, 480 V 3-phase input and Power Options

Rated Input Voltage	Rated Output Current (Amps)	Nominal HP <sup>1</sup>	UL Type 1 Configured	Power Options	
				Circuit Breaker (100 kAIC)	Input Fuse
			H6CP . . .	M	F
480 V 3-Phase	1.6	0.75	B001	-	
	2.1	1	B002		
	3.2	2	B003		
	4.8	3	B004		
	7.6	5	B007		
	11	7.5	B011		
	14	10	B014		
	21	15	B021		
	27	20	B027		
	34	25	B034		
	40	30	B040		
	52	40	B052		
	65	50	B065		
	77	60	B077		
96	75	B096			

1. Horsepower rating is based on standard NEMA B, 4-pole motor design as represented in NEC table 430.150 Full-Load Current, Three-Phase Alternating Current Motors at 480 volts.

Table 81: Control Options

Option Code	Option	Description
W	Customer Nameplate	Custom engraved nameplates with white lettering on black lamicaid are available with option (W), for special tagging purposes, for example, AHU #1. Note that this option requires the text to be specified by the customer.
3	BACnet/IP Dual Port (Multi-Protocol Ethernet Card)	Multi-Protocol Ethernet Card: BACnet/IP is the default setting.
D	EtherNet/IP Dual Port (SI-EN3D)	ODVA compliant option card to connect to EtherNet/IP.
L	LonWorks (SI-W3)	LonWorks, option (L), requires the addition of an optional board.
B	Bluetooth® Keypad	The Bluetooth® Enabled Keypad provides a wireless connection to your smartphone or tablet.

## Dimensions and Data

Table 82: 208 V UL Type 12 Packages

Rated Input Voltage	H6C Configured Base No. H6CN....	Rated Output Current (Amps)	Nominal HP	Configured Box No.	Submittal Documents (Outline Drawing) (Schematic) (Submittal Guide)	Drive Part No. HV60U	Enclosure, UL Type 12			
							Overall Dimensions (in)			Weight (lb)
							H	W	D	
208 V 3-Phase	D002	2.4	0.5	W1	DD.HC.12.W1.01 DS.H6CP.01 SG.H6CP.10	2011CVA	33	7.5	13.9	50
	D003	3.5	0.75			2011CVA				
	D004	4.6	1			2011CVA				
	D007	7.5	2			2011CVA				
	D010	10.6	3			2011CVA				
	D016	16.7	5			2017CVA				
	D024	24.2	7.5	W2	DD.HC.12.W2.01 DS.H6CP.01 SG.H6CP.10	2024CVA	36.6			56
	D030	30.8	10	2031CVA	59					
	D046	46.2	15	W3	DD.HC.12.W3.01 DS.H6CP.01 SG.H6CP.10	2046CVA	42	9.6	14.2	82
	D059	59.4	20			2059CVA				85

Table 83: 480 V UL Type 12 Packages

Rated Input Voltage	H6C Configured Base No. H6CN....	Rated Output Current (Amps)	Nominal HP	Configured Box No.	Submittal Documents (Outline Drawing) (Schematic) (Submittal Guide)	Drive Part No. HV60U	Enclosure, UL Type 12			
							Overall Dimensions (in)			Weight (lb)
							H	W	D	
480 V 3-Phase	B001	1.6	0.75	W1	DD.HC.12.W1.01 DS.H6CP.01 SG.H6CP.10	4005CVA	33.0	7.5	13.9	52
	B002	2.1	1			4005CVA				
	B003	3.4	2			4005CVA				
	B004	4.8	3			4005CVA				
	B007	7.6	5			4008CVA				
	B011	11	7.5			4011CVA				
	B014	14	10			4014CVA				
	B021	21	15	W2	DD.HC.12.W2.01 DS.H6CP.01 SG.H6CP.10	4021CVA	36.6	9.6	13.9	58
	B027	27	20			4027CVA				60
	B034	34	25			4034CVA				63
	B040	40	30	W3	DD.HC.12.W3.01 DS.H6CP.01 SG.H6CP.10	4040CVA	42.0	9.6	13.9	84
	B052	52	40			4052CVA				90

# Enclosed Configured, UL Type 1 (H6C1)



Enclosed Configured features the HV600 drive and all components housed in a UL Type 1 certified enclosure.

The HV600 Drive is a variable torque AC drive, designed specifically for HVAC applications in building automation. A new benchmark for size, cost, performance, benefits, and quality, the HV600 includes numerous built-in features such as Network Communications, H/O/A, PI control, and energy-savings functions.

The HV600 has embedded communications for the popular building automation protocols BACnet, Modbus, Siemens APOGEE, and Johnson Controls Metasys. Optional LonWorks, BACnet/IP, or EtherNet/IP interface cards are also available.

Program the drive prior to installation and upgrade firmware without the need for three-phase main power. Use the free Yaskawa Drive Cloud with the DriveWizard Mobile Application for parameter backups and wired programming with an Android smart device.

## Performance Features

- VT Ratings:
  - 0.5 to 100 HP, 208 VAC
  - 0.5 to 100 HP, 240 VAC
  - 0.5 to 250 HP, 480 VAC
- Overload capacity: 110% for 60 seconds (150% Peak)
- DC Injection braking: at start or stop, adjustable, current limited (anti-windmilling)
- Adjustable accel/decel: 0.1 to 6000 seconds
- Controlled speed range: 40:1 (V/f)
- Critical frequency rejection capability: 3 selectable, adjustable bands
- Torque limiting: 30 to 180%
- Power loss ride-through: 2 seconds
- Auto restart after power loss or resettable fault, selectable, programmable
- Serial communications loss detection
- Up/down speed control (MOP)
- Stationary motor auto-tuning
- 140% starting torque capability, available from 3 Hz to 60 Hz
- Remote speed reference (speed command) signal:
  - 0 to 10 VDC (20 K Ohm)
  - 4 to 20 mA DC (250 Ohm)
- Adjustable carrier frequency, from 1 kHz to 12.5 kHz
- 7 programmable multi-function input terminals (24 VDC) providing 60+ programmable features, including:
  - Customer safeties

- BAS / damper interlock
- Emergency Override
- Preset speed
- PID control enable / disable
- 3 programmable multi-function output relays (Form A rated 2 amps @ 250 VAC & 30 VDC), providing 50+ functions, including:
  - Damper control
  - Hand/Auto status
  - Contactor control for external bypass
  - Overtorque/undertorque detection
- One fixed, Fault, form C output relay (Rated 2 amps @ 250 VAC & 30 VDC)
- 2 Functional Safety Inputs

## Service Conditions

- Input voltage:
  - 208 VAC, 240 VAC, 480 VAC, -15/+10%
- Input frequency: 50/60 Hz  $\pm$  5%
- Ambient service temperature:
  - -10 °C to 40°C (14 °F to 104 °F)
- Ambient storage temperature: -20°C to 70°C (-4 °F to 158 °F)
- Humidity: 0% to 95% non-condensing
- Service factor: 1.0

## Design Features

- Standard configuration is a lockable main input disconnect switch and requires external branch circuit protection
- Adjustable electronic motor overload protection
- Built in 5% line impedance

- Displacement power factor of 0.98 throughout the motor speed range
- NEC rated input / output amps
- Internal EMI/RFI filter complies with IEC 61800-3 restricted distribution for first environment
- Built-In real-time clock for time and date stamping events along with timer functions for starting, stopping and speed changes without the need for external controls
- Volt meter, ammeter, kilowatt meter elapsed run time meter and heat sink temperature monitoring functions
- Drive internal PI closed-loop control with selectable engineering units
- Independent PI control for use with external device
- Differential PID feedback feature
- Sleep function in both closed-loop and open-loop control
- Feedback signal low pass filter
- Feedback signal loss detection and selectable response strategy
- Feedback signal inverse and square root capability
- 24 VDC, 150 mA power supply
- Input and output terminal status indication
- VFD efficiency: 98% at full-speed; 96% at half-speed
- Diagnostic fault indication
- S-curve soft start / soft stop capability
- Serial communication loss detection and selectable response strategy
- Serial communication status

- No load detection (broken belt alert)
- 7 preset speeds
- Built-in BACnet protocol (BTL certified)
  - BACnet Health Monitor feature for setup and troubleshooting
- Modbus/Memobus accessible via RS-422/485 communication standard
- Kinetic Energy Braking (KEB) function maintains the DC bus voltage during a power-loss by using kinetic energy from the motor
- LCD keypad: Hand-Off-Auto functions with a built-in copy feature
- Motor preheat function
- Flash upgradeable firmware
- Customizable monitor display
- Heat sink over temperature speed foldback feature

- Bumpless transfer between Hand and Auto modes
- Emergency override can be used as smoke purge function
- Fan failure detection and selectable drive action

- HCAI (OSHDP), IBC, ICC-ES AC156
  - Seismic certification is for wall mounted units only

### Ease of Use Features

- Programming and firmware upgrade without three-phase main power
- QR code for Yaskawa Drive Cloud registration
- Short circuit current rating (SCCR) on nameplate
- In box mounting templates and startup instructions

### Standards

- UL 508A (Industrial Control Panels)
- BTL listed

### Options

- Circuit Breaker (100 kAIC)
- Input Fuses
- Custom Nameplate
- BACnet/IP
- Ethernet/IP
- LonWorks
- Speed Pot
- Control Transformer (200 VA extra)
- Input Reactor
- Bluetooth®

## Catalog Code Configuration (H6C1)

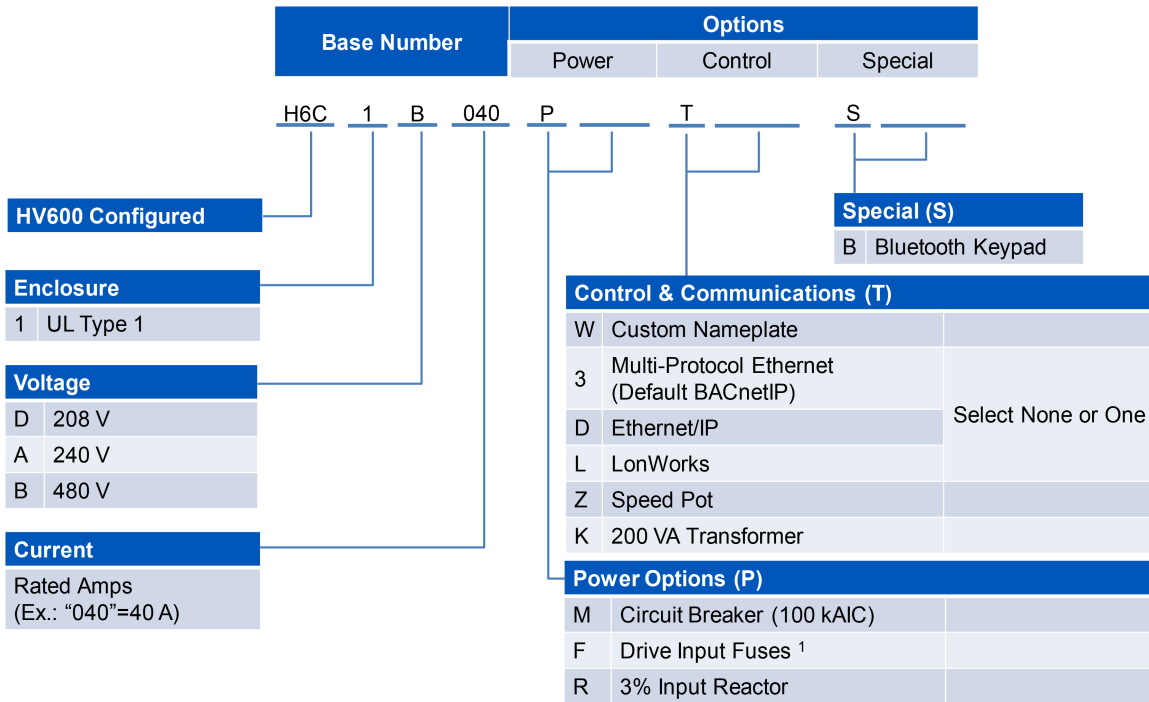

1. For drive input fuses, choose Option F. Option F is not allowed with Option M for the following packages because drive input fusing is automatically included: H6C1D211, H6C1D273, H6C1A192, H6C1A248, H6C1B180, H6C1B240, H6C1B302.

## Package Options (H6C1)

Table 84: Power Options

Option Code	Option	Description
M	Circuit Breaker	Option (M) is a 100 kAIC rated circuit breaker. When option (M) is specified, the configured drive package will be rated at 100 kAIC. <sup>1</sup>
F	Input Fuses	This option (F) provides input fuses for drive short circuit protection. <sup>2</sup>
R	Input Reactor	The standard configuration does not provide any additional AC line impedance. Option (R) can be selected to add a 3% AC line input reactor.

- When option (M) is not selected, external branch circuit protection is required to achieve desired panel short circuit current rating (kAIC) and is supplied by the customer.
- Drive input fuses provide short circuit current protection (100kAIC) for the drive and allows for a wider range of external branch circuit protection options supplied by the customer.

## Model Selection

Table 85: 208 V Models and Power Options

Rated Input Voltage	Rated Output Current (Amps)	Nominal HP <sup>1</sup>	UL Type 1 Configured	Power Options		
				Circuit Breaker (100 kAIC)	Input Fuse	Input Reactor
			H6C1. . . .	M	F	R
208 V 3-Phase	2.4	0.5	D002			
	3.5	0.75	D003			
	4.6	1	D004			
	7.5	2	D007			
	10.6	3	D010			
	16.7	5	D016			
	24.2	7.5	D024			
	30.8	10	D030			
	46.2	15	D046			
	59.4	20	D059			
	74.8	25	D074			
	88	30	D088			
	114	40	D114			
	143	50	D143			
	169	60	D169			
211	75	D211				
273	100	D273				

- Horsepower rating is based on standard NEMA B, 4-pole motor design as represented in NEC table 430.150 Full-Load Current, Three-Phase Alternating Current Motors at 208 volts.

Table 86: 240 V Models and Power Options

Rated Input Voltage	Rated Output Current (Amps)	Nominal HP <sup>1</sup>	UL Type 1 Configured	Power Options		
			H6C1 . . .	Circuit Breaker (100 kAIC)	Input Fuse	Input Reactor
				M	F	R
240 V 3-Phase	2.2	0.5	A002			
	3.2	0.75	A003			
	4.2	1	A004			
	6.8	2	A006			
	9.6	3	A009			
	15.2	5	A015			
	22	7.5	A022			
	28	10	A028			
	42	15	A042			
	54	20	A054			
	68	25	A068			
	80	30	A080			
	104	40	A104			
	130	50	A130			
	154	60	A154			
	192	75	A192			
248	100	A248				

1. Horsepower rating is based on standard NEMA B, 4-pole motor design as represented in NEC table 430.150 Full-Load Current, Three-Phase Alternating Current Motors at 240 volts.



Table 87: 480 V Models and Power Options

Rated Input Voltage	Rated Output Current (Amps)	Nominal HP <sup>1</sup>	UL Type 1 Configured	Power Options		
				Circuit Breaker (100 kAIC)	Input Fuse	Input Reactor
			H6C1 . . .	M	F	R
480 V 3-Phase	1.6	0.75	B001			
	2.1	1	B002			
	3.2	2	B003			
	4.8	3	B004			
	7.6	5	B007			
	11	7.5	B011			
	14	10	B014			
	21	15	B021			
	27	20	B027			
	34	25	B034			
	40	30	B040			
	52	40	B052			
	65	50	B065			
	77	60	B077			
	96	75	B096			
	124	100	B124			
	156	125	B156			
180	150	B180				
240	200	B240				
302	250	B302				

1. Horsepower rating is based on standard NEMA B, 4-pole motor design as represented in NEC table 430.150 Full-Load Current, Three-Phase Alternating Current Motors at 480 volts.

Table 88: Control Options

Option Code	Option	Description
W	Customer Nameplate	Custom engraved nameplates with white lettering on black lamacoids are available with option (W), for special tagging purposes, for example, AHU #1. Note that this option requires the text to be specified by the customer.
3	BACnet/IP Dual Port (Multi-Protocol Ethernet Card)	Multi-Protocol Ethernet Card: BACnet/IP is the default setting.
D	EtherNet/IP Dual Port (SI-EN3D)	ODVA compliant option card to connect to EtherNet/IP.
L	LonWorks (SI-W3)	LonWorks, option (L), requires the addition of an optional board.
Z	Speed Pot	This option provides a door-mounted Speed Pot with knob to control motor speed.
K	200 VA Transformer	200 VA Control Power Transformer (for customer use).
B	Bluetooth® Keypad	The Bluetooth® Enabled Keypad provides a wireless connection to your smartphone or tablet.

## Dimensions and Data (H6C1)

Table 89: 208 V, UL Type 1

Rated Input Voltage	HV600 Configured Base No. H6C1.... <sup>1</sup>	Rated Output Current (Amps)	Nominal HP	Configured Box No.	Submittal Documents (Outline Drawing) (Schematic) (Submittal Guide)	Drive Part No. HV60U	Enclosed, UL Type 1			
							Overall Dimensions (in)			Weight (lb)
							H	W	D	
208 V 3-Phase	D002	2.4	0.5	W0	DD.HWF.1.W0.01 DS.H6C1.01 SG.H6C1.10	2011CFA	25.9	15.7	15.6	90
	D003	3.5	0.75			2011CFA				
	D004	4.6	1			2011CFA				
	D007	7.5	2			2011CFA				
	D010	10.6	3			2011CFA				
	D016	16.7	5			2017CFA				
	D024	24.2	7.5	W1	DD.HWF.1.W1.01 DS.H6C1.01 SG.H6C1.10	2024CFA	33.9	18.7	17.6	124
	D030	30.8	10			2031CFA				133
	D046	46.2	15	W2	DD.HWF.1.W2.01 DS.H6C1.01 SG.H6C1.10	2046CFA	37.1	20.8	18.5	166
	D059	59.4	20			2059CFA				170
	D074	74.8	25	W3	DD.HWF.1.W3.01 DS.H6C1.01 SG.H6C1.10	2075CFA	42.1	25.6	18.9	221
	D088	88	30			2088CFA				228
	D114	114	40			2114CFA				240
	D143	143	50	W4	DD.HWF.1.W4.01 DS.H6C1.01 SG.H6C1.10	2143CFA	53.1	33.8	20.5	422
	D169	169	60			2169CFA				432
	D211	211	75			2211CBA				449
D273	273	100	2273CBA			515				

1. H6C1 packages with power option PR (3% reactor) are not seismic rated.

Table 90: 240 V, UL Type 1

Rated Input Voltage	HV600 Configured Base No. H6C1.... <sup>1</sup>	Rated Output Current (Amps)	Nominal HP	Configured Box No.	Submittal Documents (Outline Drawing) (Schematic) (Submittal Guide)	Drive Part No. HV60U	Enclosed, UL Type 1			
							Overall Dimensions (in)			Weight (lb)
							H	W	D	
240 V 3-Phase	A002	2.2	0.5	W0	DD.HWF.1.W0.01 DS.H6C1.01 SG.H6C1.10	2011CFA	25.9	15.7	15.6	89
	A003	3.2	0.75			2011CFA				91
	A004	4.2	1			2011CFA				
	A006	6.8	2			2011CFA				
	A009	9.6	3			2011CFA				
	A015	15.2	5			2017CFA				
	A022	22	7.5	W1	DD.HWF.1.W1.01 DS.H6C1.01 SG.H6C1.10	2024CFA	33.9	18.7	17.6	124
	A028	28	10			2031CFA				128
	A042	42	15	W2	DD.HWF.1.W2.01 DS.H6C1.01 SG.H6C1.10	2046CFA	37.1	20.8	18.5	161
	A054	54	20			2059CFA				169
	A068	68	25	W3	DD.HWF.1.W3.01 DS.H6C1.01 SG.H6C1.10	2075CFA	42.1	25.6	18.9	220
	A080	80	30			2088CFA				225
	A104	104	40			2114CFA				236
	A130	130	50	W4	DD.HWF.1.W4.01 DS.H6C1.01 SG.H6C1.10	2143CFA	53.1	33.8	20.5	412
	A154	154	60			2169CFA				431
	A192	192	75			2211CBA				447
A248	248	100	2273CBA			469				

1. H6C1 packages with power option PR (3% reactor) are not seismic rated.

Table 91: 480 V, UL Type 1

Rated Input Voltage	HV600 Configured Base No. H6C1.... <sup>1</sup>	Rated Output Current (Amps)	Nominal HP	Configured Box No.	Submittal Documents (Outline Drawing) (Schematic) (Submittal Guide)	Drive Part No. HV60U	Enclosed, UL Type 1			
							Overall Dimensions (in)			Weight (lb)
							H	W	D	
480 V 3-Phase	B1P1	1.1	0.5	W0	SG.H6C1.10 DD.HWF.1.W0.01 DS.H6C1.01	4005CFA	25.9	15.7	15.6	90
	B001	1.6	0.75			4005CFA				
	B002	2.1	1			4005CFA				
	B003	3.4	2			4005CFA				
	B004	4.8	3			4005CFA				
	B007	7.6	5			4008CFA				
	B011	11	7.5			4011CFA				
	B014	14	10			4014CFA				
	B021	21	15			W1				DD.HWF.1.W1.01 DS.H6C1.01 SG.H6C1.10
	B027	27	20	4027CFA	133					
	B034	34	25	4034CFA	139					
	B040	40	30	W2	DD.HWF.1.W2.01 DS.H6C1.01 SG.H6C1.10	4040CFA	37.1	20.8	18.5	163
	B052	52	40			4052CFA				175
	B065	65	50			4065CFA				183
	B077	77	60	W3	DD.HWF.1.W3.01 DS.H6C1.01 SG.H6C1.10	4077CFA	42.1	25.6	18.9	237
	B096	96	75			4096CFA				245
	B124	124	100			4124CFA				264
	B156	156	125	W4	DD.HWF.1.W4.01 DS.H6C1.01 SG.H6C1.10	4156CFA	53.1	33.8	20.5	439
	B180	180	150			4180CBA				463
	B240	240	200			4240CBA				490
B302	302	250	F1	DD.HWF.1.F1.01 DS.H6C1.01 SG.H6C1.10	4302CBA	87.0	42.0	33.5	980	

1. H6C1 packages with power option PR (3% reactor) are not seismic rated.

# Enclosed Configured, UL Type 12 (H6C2)



Enclosed Configured features the HV600 drive and all components housed in a UL Type 12 certified enclosure.

The HV600 Drive is a variable torque AC drive, designed specifically for HVAC applications in building automation. A new benchmark for size, cost, performance, benefits, and quality, the HV600 includes numerous built-in features such as Network Communications, H/O/A, PI control, and energy-savings functions.

The HV600 has embedded communications for the popular building automation protocols BACnet, Modbus, Siemens APOGEE, and Johnson Controls Metasys. Optional LonWorks, BACnet/IP, or EtherNet/IP interface cards are also available.

Program the drive prior to installation and upgrade firmware without the need for three-phase main power. Use the free Yaskawa Drive Cloud with the DriveWizard Mobile Application for parameter backups and wired programming with an Android smart device.

## Performance Features

- VT Ratings:
  - 0.5 to 100 HP, 208 VAC
  - 0.5 to 100 HP, 240 VAC
  - 0.5 to 250 HP, 480 VAC
- Overload capacity: 110% for 60 seconds (150% Peak)
- DC Injection braking: at start or stop, adjustable, current limited (anti-windmilling)
- Adjustable Accel/Decel: 0.1 to 6000 seconds
- Controlled speed range: 40:1 (V/f)
- Critical frequency rejection capability: 3 selectable, adjustable bands
- Torque limiting: 30 to 180%
- Power loss ride-through: 2 seconds
- Auto restart after power loss or resettable fault, selectable, programmable
- Serial communications loss detection
- Up/down speed control (MOP)
- Stationary motor auto-tuning
- 140% starting torque capability, available from 3 Hz to 60 Hz
- Remote speed reference (speed command) signal:
  - 0 to 10 VDC (20 K Ohm)
  - 4 to 20 mA DC (250 Ohm)
- Adjustable carrier frequency, from 1 kHz to 12.5 kHz
- 7 programmable multi-function input terminals (24 VDC) providing 60+ programmable features, including:
  - Customer safeties
  - BAS / damper interlock

- Emergency Override
- Preset speed
- PID control enable / disable
- 3 programmable multi-function output relays (Form A rated 2 amps @ 250 VAC & 30 VDC), providing 50+ functions, including:
  - Damper control
  - Hand/Auto status
  - Contactor control for external bypass
  - Overtorque/Undertorque detection
- One fixed, Fault, form C output relay (Rated 2 amps @ 250 VAC & 30 VDC)
- 2 Functional Safety Inputs

## Service Conditions

- Input voltage:
  - 208 VAC, 240 VAC, 480 VAC, -15/+10%
- Input frequency: 50/60 Hz  $\pm$  5%
- Ambient service temperature:
  - -10 °C to 40°C (14 °F to 104 °F)
- Ambient storage temperature: -20°C to 70°C (-4 °F to 158 °F)
- Humidity: 0% to 95% non-condensing
- Altitude: to 1000 meters (3300 feet); higher by derating
- Service factor: 1.0

## Design Features

- Standard configuration is a lockable main input disconnect switch and requires external branch circuit protection
- Adjustable electronic motor overload protection
- Built in 5% line impedance

- Displacement power factor of 0.98 throughout the motor speed range
- NEC rated input / output amps
- Internal EMI/RFI filter complies with IEC 61800-3 restricted distribution for first environment
- Built-In real-time clock for time and date stamping events along with timer functions for starting, stopping and speed changes without the need for external controls
- Volt meter, ammeter, kilowatt meter elapsed run time meter and heat sink temperature monitoring functions
- Drive internal PI closed-loop control with selectable engineering units
- Independent PI control for use with external device
- Differential PID feedback feature
- Sleep function in both closed-loop and open-loop control
- Feedback signal low pass filter
- Feedback signal loss detection and selectable response strategy
- Feedback signal inverse and square root capability
- 24 VDC, 150 mA power supply
- Input and output terminal status indication
- VFD efficiency: 98% at full-speed; 96% at half-speed
- Diagnostic fault indication
- S-curve soft start / soft stop capability
- Serial communication loss detection and selectable response strategy
- Serial communication status
- No load detection (broken belt alert)

- 7 preset speeds
- Built-in BACnet protocol (BTL certified)
  - BACnet Health Monitor feature for setup and troubleshooting
- Modbus/Memobus accessible via RS-422/485 communication standard
- Kinetic Energy Braking (KEB) function maintains the DC bus voltage during a power-loss by using kinetic energy from the motor
- LCD keypad: Hand-Off-Auto functions with a built-in copy feature
- Motor preheat function
- Flash upgradeable firmware
- Customizable monitor display
- Heat sink over temperature speed foldback feature
- Bumpless transfer between Hand and Auto modes

- Emergency override can be used as a Smoke Purge function
- Fan failure detection and selectable drive action

– Seismic certification is for wall mounted units only

### Ease of Use Features

- Programming and firmware upgrade without three-phase main power
- QR code for Yaskawa Drive Cloud registration
- Short circuit current rating (SCCR) on nameplate
- In box mounting templates and startup instructions

### Standards

- UL 508A (Industrial Control Panels)
- BTL listed
- HCAI (OSHDP), IBC, ICC-ES AC156

### Options

- Circuit Breaker (100 kAIC)
- Input Fuses
- Custom Nameplate
- BACnet/IP
- Ethernet/IP
- LonWorks
- Speed Pot
- Control Transformer (200 VA extra)
- Input Reactor
- Bluetooth®

## Catalog Code Configuration (H6C2)

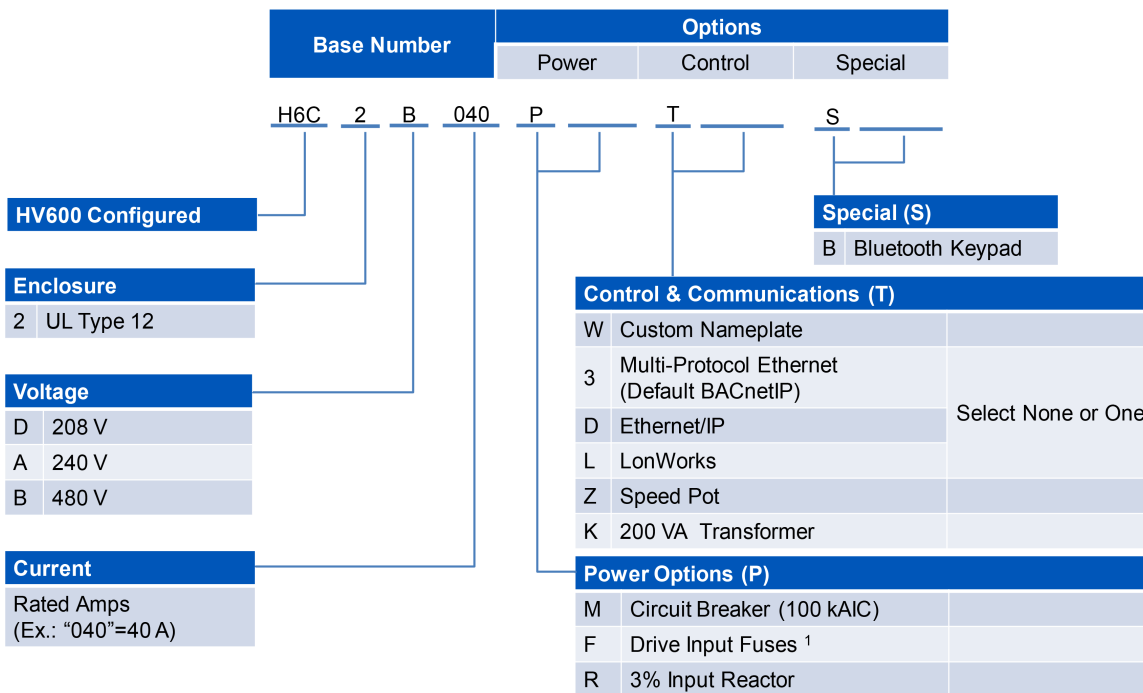

1. For drive input fuses, choose Option F. Option F is not allowed with Option M for the following packages because drive input fusing is automatically included: H6C2D211, H6C2D273, H6C2A192, H6C2A248, H6C2B180, H6C2B240, H6C2B302.

## Package Options (H6C2)

Table 92: Power Options

Option Code	Option	Description
M	Circuit Breaker	Option (M) is a 100 kAIC rated circuit breaker. When option (M) is specified, the configured drive package will be rated at 100 kAIC. <sup>1</sup>
F	Input Fuses	This option (F) provides input fuses for drive short circuit protection. <sup>2</sup>
R	Input Reactor	The standard configuration does not provide any additional AC line impedance. Option (R) can be selected to add a 3% AC line input reactor.

- When option (M) is not selected, external branch circuit protection is required to achieve desired panel short circuit current rating (kAIC) and is supplied by the customer.
- Drive input fuses provide short circuit current protection (100kAIC) for the drive and allows for a wider range of external branch circuit protection options supplied by the customer.

## Model Selection

Table 93: 208 V Models and Power Options

Rated Input Voltage	Rated Output Current (Amps)	Nominal HP <sup>1</sup>	UL Type 12 Configured	Power Options		
				Circuit Breaker (100 kAIC)	Input Fuse	Input Reactor
			H6C2. . . .	M	F	R
208 V 3-Phase	2.4	0.5	D002			
	3.5	0.75	D003			
	4.6	1	D004			
	7.5	2	D007			
	10.6	3	D010			
	16.7	5	D016			
	24.2	7.5	D024			
	30.8	10	D030			
	46.2	15	D046			
	59.4	20	D059			
	74.8	25	D074			
	88	30	D088			
	114	40	D114			
	143	50	D143			
	169	60	D169			
211	75	D211				
273	100	D273				

- Horsepower rating is based on standard NEMA B, 4-pole motor design as represented in NEC table 430.150 Full-Load Current, Three-Phase Alternating Current Motors at 208 volts.

Table 94: 240 V Models and Power Options

Rated Input Voltage	Rated Output Current (Amps)	Nominal HP <sup>1</sup>	UL Type 12 Configured	Power Options		
			H6C2. . . .	Circuit Breaker (100 kAIC)	Input Fuse	Input Reactor
				M	F	R
240 V 3-Phase	2.2	0.5	A002			
	3.2	0.75	A003			
	4.2	1	A004			
	6.8	2	A006			
	9.6	3	A009			
	15.2	5	A015			
	22	7.5	A022			
	28	10	A028			
	42	15	A042			
	54	20	A054			
	68	25	A068			
	80	30	A080			
	104	40	A104			
	130	50	A130			
	154	60	A154			
	192	75	A192			
248	100	A248				

1. Horsepower rating is based on standard NEMA B, 4-pole motor design as represented in NEC table 430.150 Full-Load Current, Three-Phase Alternating Current Motors at 240 volts.



Table 95: 480 V Models and Power Options

Rated Input Voltage	Rated Output Current (Amps)	Nominal HP <sup>1</sup>	UL Type 12 Configured	Power Options		
				Circuit Breaker (100 kAIC)	Input Fuse	Input Reactor
			H6C2. . . .	M	F	R
480 V 3-Phase	1.6	0.75	B001			
	2.1	1	B002			
	3.4	2	B003			
	4.8	3	B004			
	7.6	5	B007			
	11	7.5	B011			
	14	10	B014			
	21	15	B021			
	27	20	B027			
	34	25	B034			
	40	30	B040			
	52	40	B052			
	65	50	B065			
	77	60	B077			
	96	75	B096			
	124	100	B124			
	156	125	B156			
180	150	B180				
240	200	B240				
302	250	B302				

1. Horsepower rating is based on standard NEMA B, 4-pole motor design as represented in NEC table 430.150 Full-Load Current, Three-Phase Alternating Current Motors at 480 volts.

Table 96: Control Options

Option Code	Option	Description
W	Customer Nameplate	Custom engraved nameplates with white lettering on black lamacoid are available with option (W), for special tagging purposes, for example, AHU #1. Note that this option requires the text to be specified by the customer.
3	BACnet/IP Dual Port (Multi-Protocol Ethernet Card)	Multi-Protocol Ethernet Card: BACnet/IP is the default setting.
D	EtherNet/IP Dual Port (SI-EN3D)	ODVA compliant option card to connect to EtherNet/IP.
L	LonWorks (SI-W3)	LonWorks, option (L), requires the addition of an optional board.
Z	Speed Pot	This option provides a door-mounted Speed Pot with knob to control motor speed.
K	200 VA Transformer	200 VA Control Power Transformer (for customer use).
B	Bluetooth® Keypad	The Bluetooth® Enabled Keypad provides a wireless connection to your smartphone or tablet.

## Dimensions and Data (H6C2)

Table 97: 208 V UL Type 12

Rated Input Voltage	HV600 Configured Base No. H6C2.... <sup>1</sup>	Rated Output Current (Amps)	Nominal HP	Configured Box No.	Submittal Documents (Outline Drawing) (Schematic) (Submittal Guide)	Drive Part No. HV60U	Enclosed, UL Type 12			
							Overall Dimensions (in)			Weight (lb)
							H	W	D	
208 V 3-Phase	D002	2.4	0.5	W0	DD.HWF.12.W0.01 DS.H6C2.01 SG.H6C2.10	2011CFA	27.1	18.3	18.8	97
	D003	3.5	0.75							
	D004	4.6	1							
	D007	7.5	2							
	D010	10.6	3							
	D016	16.7	5							
	D024	24.2	7.5	W1	DD.HWF.12.W1.01 DS.H6C2.01 SG.H6C2.10	2024CFA	34.1	19.3	18.9	125
	D030	30.8	10			2031CFA				137
	D046	46.2	15	W2	DD.HWF.12.W2.01 DS.H6C2.01 SG.H6C2.10	2046CFA	37.3	24.5	19.0	180
	D059	59.4	20			2059CFA				188
	D074	74.8	25	W3	DD.HWF.12.W3.01 DS.H6C2.01 SG.H6C2.10	2075CFA	43.6	26.3	21.4	258
	D088	88	30			2088CFA				261
	D114	114	40			2114CFA				273
	D143	143	50	W4	DD.HWF.12.W4.01 DS.H6C2.01 SG.H6C2.10	2143CFA	55.0	33.3	26.3	475
	D169	169	60			2169CFA				480
	D211	211	75			2211CBA				477
D273	273	100	2273CBA			544				

1. Refer to seismic rating document VMA-53982-01C for details.

Table 98: 240 V UL Type 12

Rated Input Voltage	HV600 Configured Base No. H6C2.... <sup>1</sup>	Rated Output Current (Amps)	Nominal HP	Configured Box No.	Submittal Documents (Outline Drawing) (Schematic) (Submittal Guide)	Drive Part No. HV60U	Enclosed, UL Type 12			
							Overall Dimensions (in)			Weight (lb)
							H	W	D	
240 V 3-Phase	A002	2.2	0.5	W0	DD.HWF.12.W0.01 DS.H6C2.01 SG.H6C2.10	2011CFA	27.1	18.3	18.8	96
	A003	3.2	0.75			2011CFA				
	A004	4.2	1			2011CFA				
	A006	6.8	2			2011CFA				
	A009	9.6	3			2011CFA				
	A015	15.2	5			2017CFA				
	A022	22	7.5	W1	DD.HWF.12.W1.01 DS.H6C2.01 SG.H6C2.10	2024CFA	34.1	19.3	18.9	125
	A028	28	10			2031CFA				128
	A042	42	15	W2	DD.HWF.12.W2.01 DS.H6C2.01 SG.H6C2.10	2046CFA	37.3	24.5	19.0	175
	A054	54	20			2059CFA				187
	A068	68	25	W3	DD.HWF.12.W3.01 DS.H6C2.01 SG.H6C2.10	2075CFA	43.6	26.3	21.4	252
	A080	80	30			2088CFA				254
	A104	104	40			2114CFA				268
	A130	130	50	W4	DD.HWF.12.W4.01 DS.H6C2.01 SG.H6C2.10	2143CFA	55.0	33.3	26.3	464
	A154	154	60			2169CFA				479
	A192	192	75			2211CBA				476
A248	248	100	2273CBA			500				

1. Refer to seismic rating document VMA-53982-01C for details.

Table 99: 480 V UL Type 12

Rated Input Voltage	HV600 Configured Base No. H6C2.... <sup>1</sup>	Rated Output Current (Amps)	Nominal HP	Configured Box No.	Submittal Documents (Outline Drawing) (Schematic) (Submittal Guide)	Drive Part No. HV60U	Enclosed, UL Type 12			
							Overall Dimensions (in)			Weight (lb)
							H	W	D	
480 V 3-Phase	B1P1	1.1	0.5	W0	DD.HWF.12.W0.01 DS.H6C2.01 SG.H6C2.10	4005CFA	27.1	18.3	18.8	100
	B001	1.6	0.75			4005CFA				
	B002	2.1	1			4005CFA				
	B003	3.4	2			4005CFA				
	B004	4.8	3			4005CFA				
	B007	7.6	5			4008CFA				
	B011	11	7.5			4011CFA				
	B014	14	10			4014CFA				
	B021	21	15	W1	DD.HWF.12.W1.01 DS.H6C2.01 SG.H6C2.10	4021CFA	34.1	19.3	18.9	134
	B027	27	20			4027CFA				135
	B034	34	25			4034CFA				145
	B040	40	30	W2	DD.HWF.12.W2.01 DS.H6C2.01 SG.H6C2.10	4040CFA	37.3	24.5	19.0	181
	B052	52	40			4052CFA				193
	B065	65	50			4065CFA				200
	B077	77	60	W3	DD.HWF.12.W3.01 DS.H6C2.01 SG.H6C2.10	4077CFA	43.6	26.3	21.4	272
	B096	96	75			4096CFA				276
	B124	124	100			4124CFA				295
	B156	156	125	W4	DD.HWF.12.W4.01 DS.H6C2.01 SG.H6C2.10	4156CFA	55.0	33.3	26.3	490
	B180	180	150			4180CBA				494
	B240	240	200			4240CBA				525
B302	302	250	F1	DD.HWF.12.F1.01 DS.H6C2.01 SG.H6C2.10	4302CBA	85.4	41.3	34.4	933	

1. Refer to seismic rating document VMA-53982-01C for details.

# Enclosed Configured, UL Type 3R (H6C3)



Enclosed Configured features the HV600 drive and all components housed in a UL Type 3R certified enclosure.

The HV600 Drive is a variable torque AC drive, designed specifically for HVAC applications in building automation. A new benchmark for size, cost, performance, benefits, and quality, the HV600 includes numerous built-in features such as Network Communications, H/O/A, PI control, and energy-savings functions.

The HV600 has embedded communications for the popular building automation protocols BACnet, Modbus, Siemens APOGEE, and Johnson Controls Metasys. Optional LonWorks, BACnet/IP, or EtherNet/IP interface cards are also available.

Program the drive prior to installation and upgrade firmware without the need for three-phase main power. Use the free Yaskawa Drive Cloud with the DriveWizard Mobile Application for parameter backups and wired programming with an Android smart device.

## Performance Features

- VT Ratings:
  - 0.5 to 100 HP, 208 VAC
  - 0.5 to 100 HP, 240 VAC
  - 0.5 to 250 HP, 480 VAC
- Overload capacity: 110% for 60 seconds (150% Peak)
- DC Injection braking: at start or stop, adjustable, current limited (anti-windmilling)
- Adjustable Accel/Decel: 0.1 to 6000 seconds
- Controlled speed range: 40:1 (V/f)
- Critical frequency rejection capability: 3 selectable, adjustable bands
- Torque limiting: 30 to 180%
- Power loss ride-through: 2 seconds
- Auto restart after power loss or resettable fault, selectable, programmable
- Serial communications loss detection
- Up/down speed control (MOP)
- Stationary motor auto-tuning
- 140% starting torque capability, available from 3 Hz to 60 Hz
- Remote speed reference (speed command) signal:
  - 0 to 10 VDC (20 K Ohm)
  - 4 to 20 mA DC (250 Ohm)
- Adjustable carrier frequency, from 1 kHz to 12.5 kHz
- 7 programmable multi-function input terminals (24 VDC) providing 60+ programmable features, including:
  - Customer safeties

- BAS / damper interlock
- Emergency Override
- Preset speed
- PID control enable / disable
- 3 programmable multi-function output relays (Form A rated 2 amps @ 250 VAC & 30 VDC), providing 50+ functions, including:
  - Damper control
  - Hand/Auto status
  - Contactor control for external bypass
  - Overtorque/Undertorque detection
- One fixed, Fault, form C output relay (Rated 2 amps @ 250 VAC & 30 VDC)
- 2 Functional Safety Inputs

## Service Conditions

- Input voltage:
  - 208 VAC, 240 VAC, 480 VAC, -15/+10%
- Input frequency: 50/60 Hz  $\pm$  5%
- Ambient service temperature:
  - -10 °C to 40 °C (14 °F to 104 °F)
- Ambient storage temperature: -20 °C to 70 °C (-4 °F to 158 °F)
- Humidity: 0% to 95% non-condensing
- Service factor: 1.0

## Design Features

- Standard configuration is a lockable main input disconnect switch and requires external branch circuit protection
- Adjustable electronic motor overload protection
- Built in 5% line impedance

- Displacement power factor of 0.98 throughout the motor speed range
- NEC rated input / output amps
- Internal EMI/RFI filter complies with IEC 61800-3 restricted distribution for first environment
- Built-In real-time clock for time and date stamping events along with timer functions for starting, stopping and speed changes without the need for external controls
- Volt meter, ammeter, kilowatt meter elapsed run time meter and heat sink temperature monitoring functions
- Drive internal PI closed-loop control with selectable engineering units
- Independent PI control for use with external device
- Differential PID feedback feature
- Sleep function in both closed-loop and open-loop control
- Feedback signal low pass filter
- Feedback signal loss detection and selectable response strategy
- Feedback signal inverse and square root capability
- 24 VDC, 150 mA power supply
- Input and output terminal status indication
- VFD efficiency: 98% at full-speed; 96% at half-speed
- Diagnostic fault indication
- S-curve soft start / soft stop capability
- Serial communication loss detection and selectable response strategy
- Serial communication status

- No load detection (broken belt alert)
- 7 preset speeds
- Built-in BACnet protocol (BTL certified)
  - BACnet Health Monitor feature for setup and troubleshooting
- Modbus/Memobus accessible via RS-422/485 communication standard
- Kinetic Energy Braking (KEB) function maintains the DC bus voltage during a power-loss by using kinetic energy from the motor
- LCD keypad: Hand-Off-Auto functions with a built-in copy feature
- Motor preheat function
- Flash upgradeable firmware
- Customizable monitor display
- Heat sink over temperature speed foldback feature
- Bumpless transfer between Hand and Auto modes

- Emergency override can be used as a Smoke Purge function
- Fan failure detection and selectable drive action

– Seismic certification is for wall mounted units only

### Ease of Use Features

- Programming and firmware upgrade without three-phase main power
- QR code for Yaskawa Drive Cloud registration
- Short circuit current rating (SCCR) on nameplate
- In box mounting templates and startup instructions

### Standards

- UL 508A (Industrial Control Panels)
- BTL listed
- HCAI (OSHPD), IBC, ICC-ES AC156

### Options

- Circuit Breaker (100 kAIC)
- Input Fuses
- Custom Nameplate
- BACnet/IP
- Ethernet/IP
- LonWorks
- Speed Pot
- Control Transformer (200 VA extra)
- Input Reactor
- Space Heater
- Keypad Viewing Window
- Bluetooth®

## Catalog Code Configuration (H6C3)

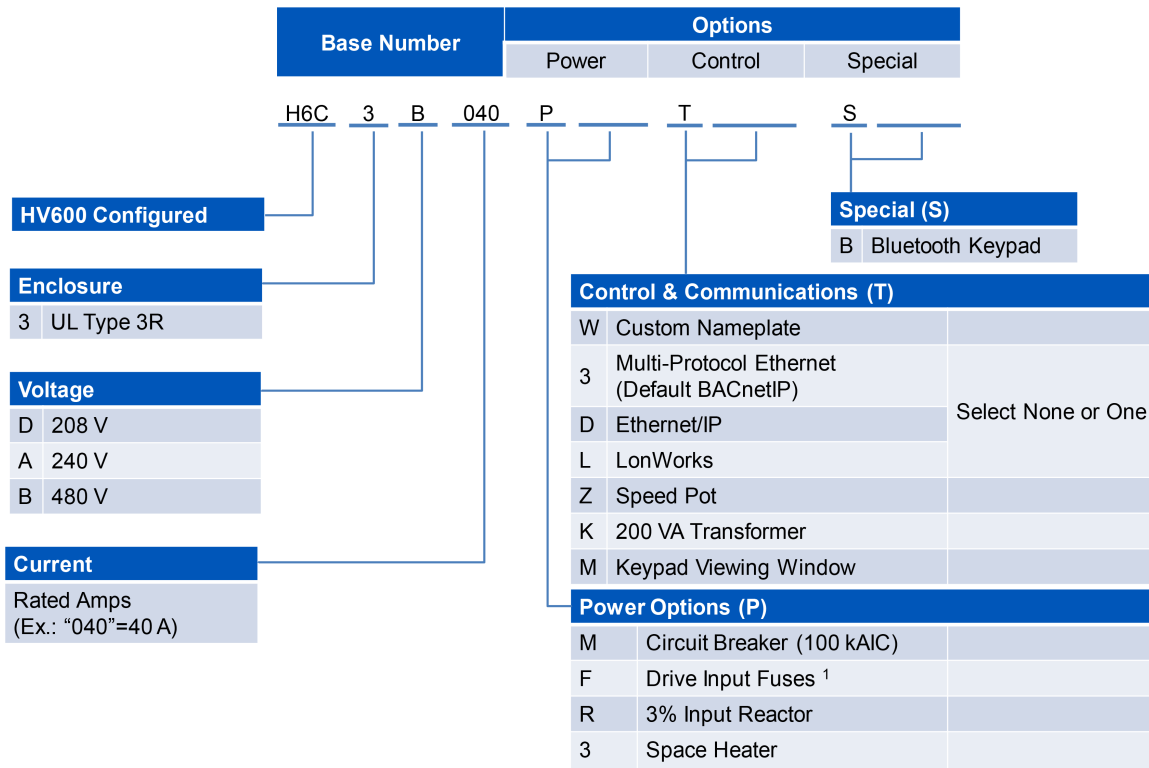

1. UL Type 3R Packages using the Option (M) do not require fusing to achieve 100 kAIC rating.

## Package Options (H6C3)

Table 100: Freestanding Leg Kit UL Type 3R

Leg Kit: This option allows the UL Type 3R wall-mount enclosures to be mounted on legs (18 or 30 inch height) so that the control can be freestanding and off the ground. Kits are purchased separate and shipped loose for field installation. Floor-mount enclosures come standard with freestanding legs.

Enclosure Size	Leg Height (in)	Part Number
W1	18	UUX002073
W2	18	UUX002078
W3	18	UUX002079
W4	18	UUX002080
W1	30	UUX002081
W2	30	UUX002082
W3	30	UUX002083
W4	30	UUX002084

Table 101: Power Options

Option Code	Option	Description
M	Circuit Breaker	Option (M) is a 100 kAIC rated circuit breaker. When option (M) is specified, the configured drive package will be rated at 100 kAIC. <sup>1</sup>
F	Input Fuses	This option (F) provides input fuses for drive short circuit protection. <sup>2</sup>
R	Input Reactor	The standard configuration does not provide any additional AC line impedance. Option (R) can be selected to add a 3% AC line input reactor.
3	Space Heater	This option helps reduce condensation.

1. When option (M) is not selected, external branch circuit protection is required to achieve desired panel short circuit current rating (kAIC) and is supplied by the customer.
2. Drive input fuses provide short circuit current protection (100kAIC) for the drive and allows for a wider range of external branch circuit protection options supplied by the customer.

## Model Selection

Table 102: 208 V Models and Power Options

Rated Input Voltage	Rated Output Current (Amps)	Nominal HP <sup>1</sup>	UL Type 3R Configured	Power Options			
				Circuit Breaker (100 kAIC)	Input Fuse	Input Reactor	Space Heater
			H6C3. . . .	M	F	R	3
208 V 3-Phase	2.4	0.5	D002				
	3.5	0.75	D003				
	4.6	1	D004				
	7.5	2	D007				
	10.6	3	D010				
	16.7	5	D016				
	24.2	7.5	D024				
	30.8	10	D030				
	46.2	15	D046				
	59.4	20	D059				
	74.8	25	D074				
	88	30	D088				
	114	40	D114				
	143	50	D143				
	169	60	D169				
211	75	D211					
273	100	D273					

1. Horsepower rating is based on standard NEMA B, 4-pole motor design as represented in NEC table 430.150 Full-Load Current, Three-Phase Alternating Current Motors at 208 volts.



Table 103: 240 V Models and Power Options

Rated Input Voltage	Rated Output Current (Amps)	Nominal HP <sup>1</sup>	UL Type 3R Configured	Power Options			
				Circuit Breaker (100 kAIC)	Input Fuse	Input Reactor	Space Heater
			H6C3. . . .	M	F	R	3
240 V 3-Phase	2.2	0.5	A002				
	3.2	0.75	A003				
	4.2	1	A004				
	6.8	2	A006				
	9.6	3	A009				
	15.2	5	A015				
	22	7.5	A022				
	28	10	A028				
	42	15	A042				
	54	20	A054				
	68	25	A068				
	80	30	A080				
	104	40	A104				
	130	50	A130				
	154	60	A154				
	192	75	A192				
248	100	A248					

1. Horsepower rating is based on standard NEMA B, 4-pole motor design as represented in NEC table 430.150 Full-Load Current, Three-Phase Alternating Current Motors at 240 volts.

Table 104: 480 V Models and Power Options

Rated Input Voltage	Rated Output Current (Amps)	Nominal HP <sup>1</sup>	UL Type 3R Configured	Power Options			
				Circuit Breaker (100 kAIC)	Input Fuse	Input Reactor	Space Heater
			H6C3. . . .	M	F	R	3
480 V 3-Phase	1.6	0.75	B001				
	2.1	1	B002				
	3.2	2	B003				
	4.8	3	B004				
	7.6	5	B007				
	11	7.5	B011				
	14	10	B014				
	21	15	B021				
	27	20	B027				
	34	25	B034				
	40	30	B040				
	52	40	B052				
	65	50	B065				
	77	60	B077				
	96	75	B096				
	124	100	B124				
	156	125	B156				
180	150	B180					
240	200	B240					
302	250	B302					

1. Horsepower rating is based on standard NEMA B, 4-pole motor design as represented in NEC table 430.150 Full-Load Current, Three-Phase Alternating Current Motors at 480 volts.

Table 105: Control Options

Option Code	Option	Description
W	Customer Nameplate	Custom engraved nameplates with white lettering on black lamacoid are available with option (W), for special tagging purposes, for example, AHU #1. Note that this option requires the text to be specified by the customer.
3	BACnet/IP Dual Port (Multi-Protocol Ethernet Card)	Multi-Protocol Ethernet Card: BACnet/IP
D	EtherNet/IP Dual Port (SI-EN3D)	ODVA compliant option card to connect to EtherNet/IP.
L	LonWorks (SI-W3)	LonWorks, option (L), requires the addition of an optional board.
Z	Speed Pot	This option provides a door-mounted Speed Pot with knob to control motor speed.
K	200 VA Transformer	200 VA Control Power Transformer (for customer use).
M	Keypad Viewing Window	The digital drive keypad is mounted on the outside of the UL Type 3R enclosure door. This option provides a viewing window that is hinged and lockable.
B	Bluetooth® Keypad	The Bluetooth® Enabled Keypad provides a wireless connection to your smartphone or tablet.

## Dimensions and Data (H6C3)

Table 106: 208 V UL Type 3R

Rated Input Voltage	HV600 Configured Base No. H6C3.... <sup>1</sup>	Rated Output Current (Amps)	Nominal HP	Configured Box No.	Submittal Documents (Outline Drawing) (Schematic) (Submittal Guide)	Drive Part No. HV60U	Enclosed, UL Type 3R			
							Overall Dimensions (in)			Weight (lb)
							H	W	D	
208 V 3-Phase	D002	2.4	0.5	W1	DD.HWF.3R.W1.01 DS.H6C3.01 SG.H6C3.10	2011CFA	39.2	18.6	18.1	150
	D003	3.5	0.75			2011CFA				
	D004	4.6	1			2011CFA				
	D007	7.5	2			2011CFA				
	D010	10.6	3			2011CFA				
	D016	16.7	5			2017CFA				
	D024	24.2	7.5			2024CFA				
	D030	30.8	10			2031CFA				
	D046	46.2	15	W2	DD.HWF.3R.W2.01 DS.H6C3.01 SG.H6C3.10	2046CFA	44.2	20.6	20.1	188
	D059	59.4	20			2059CFA				194
	D074	74.8	25	W3	DD.HWF.3R.W3.01 DS.H6C3.01 SG.H6C3.10	2075CFA	49.2	26.6	22.1	287
	D088	88	30			2088CFA				293
	D114	114	40			2114CFA				305
	D143	143	50	W4	DD.HWF.3R.W4.01 DS.H6C3.01 SG.H6C3.10	2143CFA	61.2	38.6	25.1	548
	D169	169	60			2169CFA				557
	D211	211	75	F1	DD.HWF.3R.F1.01 DS.H6C3.01 SG.H6C3.10	2211CBA	92.6	43.6	48.6	1,041
D273	273	100	2273CBA			1,092				

1. Refer to seismic rating document VMA-53982-01C for details.

Table 107: 240 V UL Type 3R

Rated Input Voltage	HV600 Configured Base No. H6C3.... <sup>1</sup>	Rated Output Current (Amps)	Nominal HP	Configured Box No.	Submittal Documents (Outline Drawing) (Schematic) (Submittal Guide)	Drive Part No. HV60U	Enclosed, UL Type 3R			
							Overall Dimensions (in)			Weight (lb)
							H	W	D	
240 V 3-Phase	A002	2.2	0.5	W1	DD.HWF.3R.W1.01 DS.H6C3.01 SG.H6C3.10	2011CFA	39.2	18.6	18.1	150
	A003	3.2	0.75							
	A004	4.2	1							
	A006	6.8	2							
	A009	9.6	3							
	A015	15.2	5							
	A022	22	7.5							
	A028	28	10							
	A042	42	15	W2	DD.HWF.3R.W2.01 DS.H6C3.01 SG.H6C3.10	2046CFA	44.2	20.6	20.1	184
	A054	54	20			2059CFA				193
	A068	68	25	W3	DD.HWF.3R.W3.01 DS.H6C3.01 SG.H6C3.10	2075CFA	49.2	26.6	22.1	285
	A080	80	30			2088CFA				287
	A104	104	40			2114CFA				300
	A130	130	50	W4	DD.HWF.3R.W4.01 DS.H6C3.01 SG.H6C3.10	2143CFA	61.2	38.6	25.1	535
	A154	154	60			2169CFA				555
	A192	192	75	F1	DD.HWF.3R.F1.01 DS.H6C3.01 SG.H6C3.10	2211CBA	93.5	43.6	48.6	1,014
	A248	248	100			2273CBA				1,049

1. Refer to seismic rating document VMA-53982-01C for details.

Table 108: 480 V UL Type 3R

Rated Input Voltage	HV600 Configured Base No. H6C3.... <sup>1</sup>	Rated Output Current (Amps)	Nominal HP	Configured Box No.	Submittal Documents (Outline Drawing) (Schematic) (Submittal Guide)	Drive Part No. HV60U	Enclosed, UL Type 3R			
							Overall Dimensions (in)			Weight (lb)
							H	W	D	
480 V 3-Phase	B1P1	1.1	0.50	W1	DD.HWF.3R.W1.01 DS.H6C3.01 SG.H6C3.10	4005CFA	39.2	18.6	18.1	151
	B001	1.6	0.75			4005CFA				
	B002	2.1	1			4005CFA				
	B003	3.4	2			4005CFA				
	B004	4.8	3			4005CFA				
	B007	7.6	5			4008CFA				155
	B011	11	7.5			4011CFA				
	B014	14	10			4014CFA				
	B021	21	15			4021CFA				
	B027	27	20			4027CFA				
	B034	34	25	4034CFA	171					
	B040	40	30	W2	DD.HWF.3R.W2.01 DS.H6C3.01 SG.H6C3.10	4040CFA	44.2	20.6	20.1	185
	B052	52	40			4052CFA				198
	B065	65	50			4065CFA				205
	B077	77	60	W3	DD.HWF.3R.W3.01 DS.H6C3.01 SG.H6C3.10	4077CFA	49.2	26.6	22.1	300
	B096	96	75			4096CFA				308
	B124	124	100			4124CFA				334
	B156	156	125	W4	DD.HWF.3R.W4.01 DS.H6C3.01 SG.H6C3.10	4156CFA	61.2	38.6	25.1	566
	B180	180	150	F1	DD.HWF.3R.F1.01 DS.H6C3.01 SG.H6C3.10	4180CBA	93.5	43.6	48.6	1,026
	B240	240	200			4240CBA				1,070
B302	302	250	4302CBA			1,189				

1. Refer to seismic rating document VMA-53982-01C for details.

## Redundant Drive Packages (H6R)



The HV600 Redundant Drive Package is engineered for use in critical HVAC building automation applications that require continuous reliable motor control.

The redundant drive package provides two HV600 drives containing HVAC application-specific software macros and a real time clocks in a UL Type 1 or UL Type 12 enclosure to ensure uninterrupted operation no matter the environment.

The redundant drive package features a main input disconnect switch, semiconductor fuses for each drive, single input/output wiring points, a single control wiring point, two door-mounted keypads, a selectable Manual or Auto Transfer switch, an H/O/A switch, and an integral damper control circuit.

Popular building automation communication protocols BACnet, Siemens APOGEE, Johnson Controls Metasys, and MEMOBUS/ Modbus are embedded in the drive. Interface cards for LonWorks, BACnet/IP, and EtherNet/IP communications are offered separately.

### Performance Features

- VT Ratings:
  - 5 to 250 HP, 480 VAC
- Overload capacity: 110% for 60 seconds (150% Peak)
- DC Injection braking: at start or stop, adjustable, current limited (anti-windmilling)
- Adjustable Accel/Decel: 0.1 to 6000 seconds
- Critical frequency rejection capability: 3 selectable, adjustable bands
- Auto restart after power loss or resettable fault, selectable, programmable
- Up/down floating point control capability
- Stationary motor auto-tuning
- 140% starting torque capability, available from 3 Hz to 60 Hz
- Remote speed reference (speed command) signal:
  - 0 to 10 VDC (20 K Ohm)
  - 4 to 20 mA DC (250 Ohm)
- Adjustable carrier frequency, from 1 kHz to 12.5 kHz
- 7 programmable multi-function input terminals (24 VDC) providing 60+ programmable features, including:
  - Customer safeties
  - BAS / damper interlock
  - Emergency Override
  - Preset speed
  - PID control enable / disable

- 3 programmable multi-function output relays (Form A rated 2 amps @ 250 VAC & 30 VDC), providing 50+ functions, including:
  - Damper control
  - Hand/Auto status
  - Contactor control for external bypass
  - Overtorque/Undertorque detection
- One fixed, Fault, form C output relay (Rated 2 amps @ 250 VAC & 30 VDC)
- 2 Functional Safety Inputs

### Service Conditions

- Input voltage:
  - 480 VAC, -15/+10%
- Input frequency: 50/60 Hz  $\pm$  5%
- Ambient service temperature:
  - -10 °C to 40°C (14 °F to 104 °F)
- Ambient storage temperature: -20°C to 70°C (-4 °F to 158 °F)
- Humidity: 0% to 95% non-condensing
- Service factor: 1.0

### Design Features

- Standard configuration is a lockable main input disconnect switch and requires external branch circuit protection
- Adjustable electronic motor overload protection
- Built in 5% line impedance

- Displacement power factor of 0.98 throughout the motor speed range
- NEC rated input / output amps
- Internal EMI/RFI filter complies with IEC 61800-3 restricted distribution for first environment
- Built-In real-time clock for time and date stamping events along with timer functions for starting, stopping and speed changes without the need for external controls
- Volt meter, ammeter, kilowatt meter elapsed run time meter and heat sink temperature monitoring functions
- Drive internal PI closed-loop control with selectable engineering units
- Independent PI control for use with external device
- Differential PID feedback feature
- Sleep function in both closed-loop and open-loop control
- Feedback signal low pass filter
- Feedback signal loss detection and selectable response strategy
- Feedback signal inverse and square root capability
- 24 VDC, 150 mA power supply
- Input and output terminal status indication
- VFD efficiency: 98% at full-speed; 96% at half-speed
- Diagnostic fault indication
- S-curve soft start / soft stop capability

- Serial communication loss detection and selectable response strategy
- Serial communication status
- No load detection (broken belt alert)
- 7 preset speeds
- Built-in BACnet protocol (BTL certified)
  - BACnet Health Monitor feature for setup and troubleshooting
- Modbus/Memobus accessible via RS-422/485 communication standard
- Kinetic Energy Braking (KEB) function maintains the DC bus voltage during a power-loss by using kinetic energy from the motor
- LCD keypad: Hand-Off-Auto functions with a built-in copy feature

- Motor preheat function
- Flash upgradeable firmware
- Customizable monitor display
- Heat sink over temperature speed foldback feature
- Bumpless transfer between Hand and Auto modes
- Emergency override can be used as a Smoke Purge function
- Fan failure detection and selectable drive action

### Ease of Use Features

- Programming and firmware upgrade without three-phase main power

- QR code for Yaskawa Drive Cloud registration
- Short circuit current rating (SCCR) on nameplate

### Standards

- UL 508A (Industrial Control Panels)
- BTL listed

### Options

- Circuit Breaker (100 kAIC)
- Custom Nameplate
- BACnet/IP
- Ethernet/IP
- LonWorks

## Catalog Code Configuration (H6R)

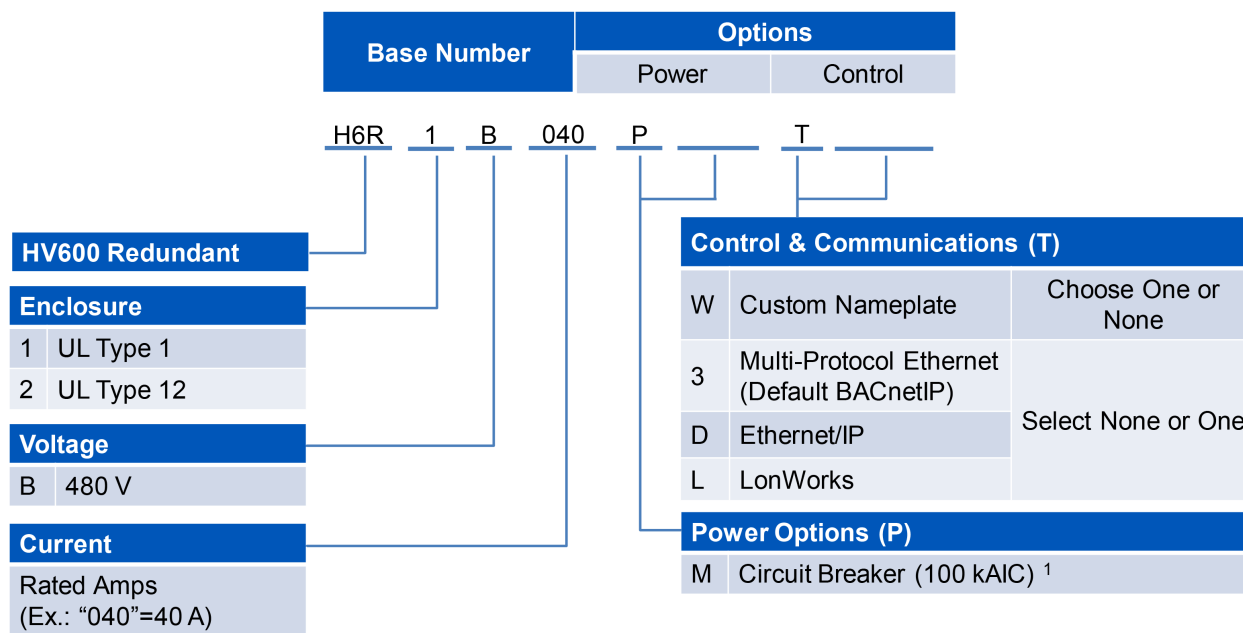

## Package Options (H6R)

Table 109: Power Options

Option Code	Option	Description
M	Circuit Breaker	Option (M) is a 100 kAIC rated circuit breaker. When option (M) is specified, the configured drive package will be rated at 100 kAIC. <sup>1</sup>

1. When option (M) is not selected, external branch circuit protection is required to achieve desired panel short circuit current rating (kAIC) and is supplied by the customer.

## Model Selection

Table 110: 480 V Type 1 Packages

Rated Voltage	Rated Output Current	Nominal HP	Configuration	Power Options
			H6R1	Circuit Breaker
				M
480 V 3-Phase	4.8	3	B005	-
	7.6	5	B008	
	11	7.5	B011	
	14	10	B014	
	21	15	B021	
	27	20	B027	
	34	25	B034	
	40	30	B040	
	52	40	B052	
	65	50	B065	
	77	60	B077	
	96	75	B096	
	124	100	B124	
	156	125	B156	
	180	150	B180	
240	200	B240		
302	250	B302		



Table 111: 480 V Type 12 Packages

Rated Voltage	Rated Output Current	Nominal HP	Configuration	Power Options
			H6R2	Circuit Breaker
				M
480 V 3-Phase	5	3	B005	-
	8	5	B008	
	11	7.5	B011	
	14	10	B014	
	21	15	B021	
	27	20	B027	
	34	25	B034	
	40	30	B040	
	52	40	B052	
	65	50	B065	
	77	60	B077	
	96	75	B096	
	124	100	B124	
	156	125	B156	
	180	150	B180	
240	200	B240		
302	250	B302		

Table 112: Control Options

Option Code	Option	Description
W	Customer Nameplate	Custom engraved nameplates with white lettering on black lamacoid are available with option (W), for special tagging purposes, for example, AHU #1. Note that this option requires the text to be specified by the customer.
3	BACnet/IP Dual Port (Multi-Protocol Ethernet Card)	Multi-Protocol Ethernet Card: BACnet/IP is the default setting. <sup>1</sup>
D	EtherNet/IP Dual Port (SI-EN3D)	ODVA compliant option card to connect to EtherNet/IP. <sup>1</sup>
L	LonWorks (SI-W3)	LonWorks, option (L), requires the addition of an optional board. <sup>1</sup>

1. List price reflects two (2) network control options, one option installed on each drive within the redundant drive package.

## Dimensions and Data (H6R)

Table 113: 480 V UL Type 1 and Type 12

Rated Input Voltage	HV600 Redundant H6R. . . .	Rated Output Current (Amps)	Nominal HP	Configured Box No.	Submittal Documents (Outline Drawing) (Schematic) (Submittal Guide)	Drive Part No. HV60U	Enclosed, UL Type 1/12				
							Overall Dimensions (in)			Type 1 Weight (lb)	Type 12 Weight (lb)
							H	W	D		
480 V 3-Phase	B005	5	3	W3	DD.H6R.112.W3.01 DS.H6R112.01 SG.H6R.10	HV60U4005CFA	43.6	26.3	21.4	183	192
	B008	8	5			HV60U4008CFA				183	192
	B011	11	7.5			HV60U4011CFA				183	192
	B014	14	10			HV60U4014CFA				183	192
	B021	21	15			HV60U4021CFA				187	195
	B027	27	20			HV60U4027CFA				187	195
	B034	34	25			HV60U4034CFA				204	212
	B040	40	30	W4	DD.H6R.112.W4.01 DS.H6R112.01 SG.H6R.10	HV60U4040CFA	55.0	33.3	26.3	295	311
	B052	52	40			HV60U4052CFA				315	330
	B065	65	50			HV60U4065CFA				328	344
	B077	77	60			HV60U4077CFA				405	418
	B096	96	75			HV60U4096CFA				428	441
	B124	124	100			HV60U4124CFA				461	474
	B156	156	125	F1	DD.H6R.112.F1.01 DS.H6R112.01 SG.H6R.10	HV60U4156CFA	85.4	41.3	34.2	991	1,001
	B180	180	150			HV60U4180CBA				997	1,010
	B240	240	200	Contact Yaskawa		HV60U4240CBA	Contact Yaskawa				
	B302	302	250	Contact Yaskawa		HV60U4302CBA	Contact Yaskawa				

# Z1000U Matrix Drive



The Z1000U HVAC MATRIX drive combines superior harmonic mitigation, input power factor control, and energy saving capabilities in a design specifically suited for use in building automation applications requiring reliable motor control.

The Z1000U HVAC MATRIX drive incorporates MATRIX technology to directly convert input AC voltage to output AC voltage. The Z1000U HVAC MATRIX drive offers real choices and benefits for green HVAC applications, and features HVAC application-specific software macros, a Hand-Off-Auto LCD keypad, and a real-time clock for system accuracy.

Popular building automation communication protocols, BACnet (BTL certified), Siemens APOGEE FLN, Johnson Controls Metasys N2, and MEMOBUS/Modbus are embedded in the drive. Interface cards for LonWorks and EtherNet/IP communications are offered separately.

## Performance Features

- VT Ratings:
  - 200 to 240 VAC, 10 to 100 HP
  - 380 to 480 VAC, 7.5 to 350 HP
- V/f Control, Open Loop Vector Control for PM
- Overload capacity: 120% for 60 seconds
- 0-400 Hz Output Frequency
- DC Injection braking: at start or stop, adjustable, current limited (anti-windmilling)
- Adjustable Accel/Decel: 0.1 to 6000 seconds
- Controlled speed range: 40:1 (V/f)
- Critical frequency rejection capability: 3 selectable, adjustable bands
- Torque limiting: 0 to 300%
- Auto restart after power loss or resettable fault, selectable, programmable
- Up/down floating point control capability
- Stationary motor auto-tuning
- 150% starting torque, available from 3 to 60 Hz
- Remote speed reference (speed command) signal:
  - 0 to 10 VDC/-10 to 10 VDC (20 K Ohms)
  - 4 to 20 mA/0 to 20 mA DC (250 Ohms)
- Adjustable carrier frequency, from 4 kHz to 10 kHz
- Programmable security code
- 8 programmable multi-function input terminals (24 VDC) providing 60+ programmable features, including:
  - Customer Safeties
  - BAS / Damper Interlock
  - Emergency Override
  - Preset Speed
  - PI control enable / disable
- 2x form A and 1x form C programmable multi-function output relays (Rated 1 amp @ 250 VAC & 30 VDC), providing 50+ functions, including:
  - Damper control
  - Hand/Auto Status
  - Contactor Control for External Bypass
  - Overtorque/Undertorque detection
- 140% starting torque capability, available from 3 Hz to 60 Hz
- Remote speed reference (speed command) signal:
  - 0 to 10 VDC (20 K Ohm)
  - 0 to 20 mA DC (250 Ohm)
  - 4 to 20 mA DC (250 Ohm)
- 7 programmable multi-function input terminals (24 VDC) providing 60+ programmable features, including:
  - Customer safeties
  - BAS / damper interlock
  - Emergency Override
  - Preset speed
  - PID control enable / disable
- 3 programmable multi-function output relays (Form A rated 2 amps @ 250 VAC & 30 VDC), providing 50+ functions, including:
  - Damper control
  - Hand/Auto status
  - Contactor control for external bypass
  - Overtorque/Undertorque detection
- Voltmeter, ammeter, kilowatt meter, elapsed run time meter, and heat sink temperature monitoring functions
- Two internal PID closed-loop control with selectable engineering units
- Independent PID control for use with external device
- 200 to 240 VAC, 380 to 480 VAC, -15/+10%
- Input frequency: 50/60 Hz  $\pm$ 3% (Frequency fluctuation rate: 1 Hz/100 ms or less)
- Ambient service temperature, Open Type (IP00), -10 °C to 50 °C (14 °F to 122 °F)
- Humidity: 0% to 95% non-condensing
- Altitude: to 1000 meters; higher by derating
- Service factor: 1.0
- Vibration: 10 to 20 Hz: 9.8 m/s<sup>2</sup> 20 to 55 Hz: 5.9 m/s<sup>2</sup> (2E0028 to 2E0081 and 4E0011 to 4E0077), 2.0 m/s<sup>2</sup> (2E0104 to 2E0248 and 4E0096 to 4E0414)

## Design Features

- Displacement power factor of 0.98 throughout the motor speed range
- Standard LCD Multi-lingual keypad, Full-text, Hand-Off-Auto with Copy (Read/Write) Function
- Built-In real-time clock for time and date stamping events along with timer functions for starting, stopping and speed changes without the need for external controls
- Volt meter, ammeter, kilowatt meter elapsed run time meter and heat sink temperature monitoring functions
- Two internal (PID) Controls
- Drive internal PID closed-loop control with selectable engineering units
- Independent PID control for use with external device
- Differential PID feedback feature
- Sleep function in both closed-loop and open-loop control
- Feedback signal low pass filter
- Feedback signal loss detection and selectable response strategy

## Service Conditions

- Input voltage:

- Feedback signal inverse and square root capability
- Input and output terminal status indication
- Diagnostic fault indication
- VFD efficiency: 96% at half-speed; 98% at full-speed
- S-curve soft start / soft stop capability
- Serial communication loss detection and selectable response strategy
- Serial communication status
- No load detection (broken belt alert)
- One fixed, Fault, form C output relay (Rated 1 amp @ 250 VAC & 30 VDC)
- 6 preset speeds
- Built-in BACnet (BTL certified), Siemens APOGEE FLN, Johnson Controls Metasys N2, and MEMOBUS/Modbus communication
- Eco-Mode to achieve near across-the-line THD and quietest operation
- Energy Savings Monitor
- Motor preheat function
- Flash upgradeable firmware

- Customizable monitor display
- Heat sink over temperature speed foldback feature
- Bumpless transfer between Hand and Auto modes
- Emergency override can be used as a Smoke Purge function
- Fan failure detection and selectable drive action
- Built-in EMC Filter
- Built-in line fuses, 100 kAIC
- Energy Savings – Low Power Loss Design
- Compact Package
- Unity Power Factor Control
- <5% TDD Harmonic Characteristics
- Low Harmonics over Wide Speed Range
- DriveWizard HVAC Software
- Removable Terminal Block with Memory
- High Reliability with an MTBF of 28 Years
- Short Circuit Withstand Rating: 100K RMS

- Optimal Speed Command Search

## Standards

- UL 508C (Power Conversion)
- CSA 22.2 No. 14-95 (Industrial Control Equipment)
- UL 1995 (Plenum)
- CE mark 2006/95/EC LVD
- CE mark 2004/108/EC
- IEC 61800-5-1 (LVD)
- EN 61800-3
- IEC 529
- IEEE C62.41
- UL, cUL listed; CE marked

## Options

- LonWorks Interface
- EtherNet/IP
- Modbus TCP/IP

## Catalog Code Configuration (Z1000U)

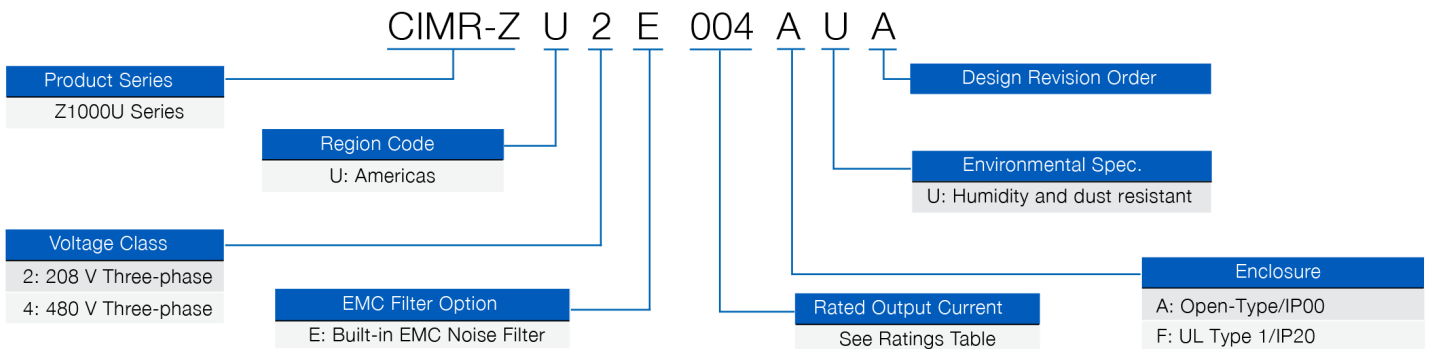

Table 114: Z1000U Model Selection 200 to 240 V

Rated Input Voltage	Rating		Standard Protection
	Rated Output Amps <sup>1 2</sup>	HP <sup>3</sup> 240 V (208 V)	Model Number CIMR-ZU2E□□□□AUA With built-in EMC noise filter.
200 to 240 V 3-Phase	28	10 (7.5)	0028
	42	15 (10)	0042
	54	20 (15)	0054
	68	25 (20)	0068
	81	30 (25)	0081
	104	40 (30)	0104
	130	50 (40)	0130
	154	60 (50)	0154
	192	75 (60)	0192
	248	100 (75)	0248

1. The rated output current of the drive should be equal to or greater than the motor rated current.
2. Carrier frequency is set to 4 kHz. Current derating is required to raise the carrier frequency.
3. Horsepower rating is based on standard NEMA B, 4-pole motor design as represented in NEC table 430.150 Full-Load Current, Three-Phase Alternating Current Motors at (208) or 240 volts.

Table 115: Z1000U Model Selection 380 to 480 V

Rated Input Voltage	Rating		Standard Protection
	Rated Output Amps <sup>1 2</sup>	Rated Output Amps <sup>3</sup>	Model Number CIMR-ZU4E□□□□AUA With built-in EMC noise filter.
380 to 480 V 3-Phase	11	7.5	0011
	14	10	0014
	21	15	0021
	27	20	0027
	34	25	0034
	40	30	0040
	52	40	0052
	65	50	0065
	77	60	0077
	96	75	0096
	124	100	0124
	156	125	0156
	180	150	0180
	216	175	0216
	240	200	0240
	302	250	0302
	361	300	0361
	414	350	0414

1. The rated output current of the drive should be equal to or greater than the motor rated current.
2. Carrier frequency is set to 4 kHz. Current derating is required to raise the carrier frequency.
3. Horsepower rating is based on standard NEMA B, 4-pole motor design as represented in NEC table 430.150 Full-Load Current, Three-Phase Alternating Current Motors at 480 volts.

## Z1000U Matrix Options

### UL Type 1 End Cap Kits

This option consists of a top and bottom cover to convert a protected IP00/Open Type drive to a IP20/NEMA 1, UL Type 1 enclosed unit. This option DOES NOT provide additional space for mounting auxiliary components for example, circuit breakers, input fuses, or reactors.

Rated Input Voltage	Drive Model Number CIMR-ZU2E . . . AUA	Part Number
200 to 240 V 3-Phase	0028	EZZ022745A
	0042 0054 0068 0081	EZZ022745B
	0104 0130	EZZ022745C
	0154 0192	EZZ022745D
	0248	EZZ022745E
Rated Input Voltage	Drive Model Number CIMR-ZU4E . . . AUA	Part Number
380 to 480 V 3-Phase	0011 0014 0021 0027 0034	EZZ022745A
	0040 0052 0065 0077	EZZ022745B
	0096 0124	EZZ022745C
	0156 0180	EZZ022745D
	0216 0240	EZZ022745E
	0302 0361 0414	EZZ022745F

## 24 VDC Control Power Unit

This option provides board-level component voltages for the Z1000 drive when provided with 24 VDC from an external, customer-supplied source. It is used to maintain both drive control power and network communications (when utilized). Option kits for customer mounting:

Model No.	Option Name	Description
PS-U10L	24 V Control Power (200 V Drives)	The 24 V Power Supply option supplies the drive control circuit with power when there is no main circuit power. The option provides external power to the control circuit only. It will not provide power to the drive main circuit. The option lets users access network communications, digital operator navigation, I/O data, and read fault and parameter data
PS-U10H	24 V Control Power (400 V Drives)	

## UL Type External Heatsink Kits

External Heatsink Kit: Allows drives to be mounted with the drive's heatsink external (UL Type 1 backside) to the enclosure. Option kit for customer mounting. Larger standard drives include brackets

Rated Input Voltage	Drive Model Number CIMR-ZU□□□□□□AUA	Part Number
200 to 240 V 3-Phase	0028	UUX001072
	0042	UUX001073
	0054	
	0068	
	0081	
	0104	UUX001074
	0130	UUX001075
	0154	
	0192	
	0248	Required brackets are included with the drive.

Rated Input Voltage	Drive Model Number CIMR-ZU□□□□□□□□AUA	Part Number
380 to 480 V 3-Phase	0011	UUX001072
	0014	
	0021	
	0027	
	0034	
	0040	UUX001073
	0052	
	0065	
	0077	UUX001074
	0096	
	0124	UUX001075
	0156	
	0180	Required brackets are included with the drive.
	0216	
	0240	
	0302	
	0361	
0414		



## Control and Communication Options

These cards, cables, and devices add control functionality to the standard drive. Items are shipped loose, unmounted.

Table 116: Digital Operator and Software

Model No.	Option Name	Description
UOP00016 (JVOP-183)	Digital Operator (LCD)	<p>This option is the standard digital operator found on the drive. This option is only required if the original digital operator is lost or damaged. If used as a remote operator, the standard digital operator may be used, but then requires Installation Set A (EZZ020642A) for panel or door mounting and Remote Operator Cable (UWR0051 or UWR0052), each sold separately. Features include:</p> <ul style="list-style-type: none"> <li>• LCD keypad display, 5 lines x 16 characters, backlit</li> <li>• 7 languages</li> <li>• Copy function</li> <li>• Mounts to RJ-45 keypad port</li> </ul>
EZZ020642A	LCD/LED Keypad Installation Set A (Remote Operator Mounting Bracket Kit)	This is a bracket to which the LCD Digital Remote Operator (JVOP-183) attaches, and has (4) threaded holes and screws to attach to the cover of an enclosure. The kit contains (2) screws to mount the Operator to the bracket and (4) screws to attach the bracket to the enclosure.
EZZ020642B	LCD/LED Keypad Installation Set B (Remote Operator Mounting Bracket Kit)	Contains a similar bracket that the keypad attaches to and has non-threaded holes for mounting to an enclosure that has the screws attached to the enclosure already. The kit contains (2) screws to mount the keypad to the bracket and (4) nuts to attach the bracket to the customer supplied screws attached to the enclosure.
UUX000922	Keypad Adapter Kit	This kit can be used when a new Z1000 keypad is replacing an old style keypad used with E7-based Z1000 drives. This kit will allow enclosure door mounted key pad to be upgraded from E7 style to the Z1000 style digital key pad.
UWR0051	Operator Cable, Remote (1 meter)	These cables are used to connect the Remote Digital Operator (JVOP-180). They are available in one (1) or three (3) meter lengths.
UWR0052	Operator Cable, Remote (3 meter)	

Model No.	Option Name	Description
UUX000526 (Blank Membrane)	Operator Kits, NEMA Type 3R/4X	This option is used to extend an LCD or LED Digital Remote Operator to the wall of a separately specified, oversized UL Type 3R, 4, 4X, or 12 enclosure (IPX6 environment). Item includes a faceplate bezel with digital operator brackets and membrane to cover the operator cutout in the enclosure door, a 3-foot cable, a 10-foot cable, and a 1:1 template for cutting the necessary cutouts in the enclosure. Keypad can be removed after kit installation. Designed for use with 1000 series Digital Remote Operators (sold separately). Connects to RJ-45 port and mounts to enclosure wall.
UUX000527 (Yaskawa Logo Membrane)		
UNP00233-3 (Yaskawa Logo)	Overlay, Keypad, Self-adhesive	This membrane is used to cover the operator cutout in the enclosure door to which the keypad has been remotely mounted.
UNP00233-5 (Blank)		
UOP000017 (Yaskawa Logo Faceplate Membrane)	UL Rated Remote Outdoor Operator / Mounting Kit	UL Rated Remote Outdoor Operator / Mounting Kit. This option provides all you will need to remotely mount the drive's Digital Operator to the door/wall of a separately specified, oversized UL Type 1, 3R, 4, 4X, or 12 enclosure (IPX6 environment). This kit includes: One JVOP-183R Digital Operator providing RTC, HOA, and outdoor rated LCD display, a faceplate bezel with digital operator brackets and membrane to cover the operator cutout in the enclosure door, a 3-foot cable, a 10-foot cable, and a 1:1 template for cutting the necessary cutouts in the enclosure. Mounting hardware is included. Keypad can be removed after kit installation. Connects to RJ-45 port and mounts to enclosure wall.
UOP000019 (Blank Faceplate Membrane)		
SW.DW.40	DriveWizard HVAC Software	This optional software package allows upload and download of parameters via PC for data storage and for programming multiple drives. The software also includes graphing and monitoring tools. It is a Windows-based program designed to make startup, commissioning, and troubleshooting the drive as simple as possible. Refer to our website at <a href="http://www.yaskawa.com">www.yaskawa.com</a> to download the software, and for more information, including minimum system requirements and cable information to interface a PC to the drive.
UWR-0638	USB Interface Cable	This 10-foot male USB-A to male USB-B cable provides a USB connection from a PC to the drive.
UWR01076-1	Flash Write Cable	This 6-foot cable connects a PC's 9-pin serial port to the drive's keypad port for updating the drive's firmware, flashing with custom firmware, or updating a network communication option board. It is used with the Flash Tool feature of the DriveWizard HVAC software.
UWR00468-2	PC Interface Cable	This 6-foot cable interconnects the drive keypad port to the 9-pin communication port on a PC. This cable is used in conjunction with DriveWizard HVAC software.

Table 117: Support Tools

Model No.	Option Name	Description
JVOP-181	USB Copy Unit (Y-Stick)	This option allows the drive to connect to the USB port on a PC. It can read, copy and verify drive parameter settings from one drive to another like drive. The unit plugs into the RJ-45 port on the front of the digital operator. Refer to our website at <a href="http://www.yaskawa.com">www.yaskawa.com</a> to download the software.
No Model Number	Copy Unit Manager Software for USB Copy Unit (Y-Stick)	This option allows the user to transfer and save parameter files from the Copy Unit (JVOP-181), sold separately, to a PC and vice versa. Refer to our website at <a href="http://www.yaskawa.com">www.yaskawa.com</a> to download the software.

Table 118: Network Communications

Model No.	Option Name	Description
SI-W3	LonWorks	This option is compatible with the LonMark Interoperability Association and complies with the Functional Profile for a Variable Frequency Motor Drive. Network connectivity is facilitated by either a Phoenix-style screw termination or RJ-45 connector. Mounts at option connector CN5-A.
SI-EN3	EtherNet/IP	This option complies with the EtherNet/IP protocol specification, and allows for communication over 10/100 Mbps Ethernet networks. This option has the ability to configure the IP Address from a user specified IP address, from a DHCP host, or from a BootP host. The IP address can be set from the drive keypad or from the network. All parameters, diagnostics, and operational commands are accessible via EtherNet/IP. The web interface allows management of diagnostic information through a standard web browser. The embedded web pages include the main page, drive status page, network monitor page, and documentation page. Mounts at option connector CN5-A.
SI-EM3	Modbus TCP/IP	This option complies with the Modbus TCP/IP protocol specification. This allows for Modbus communication over 10/100 Mbps Ethernet networks. This option has the ability to configure the IP Address from a user-specified IP address, from a DHCP host, or from a BootP host. All parameters, diagnostics, and operational commands are accessible via Modbus TCP/IP. This option supports up to 10 simultaneous PLC/PC connections. Mounts at option connector CN5-A.
SI-EN3D	EtherNet/IP with device level ring (DLR)	This option complies with the EtherNet/IP protocol specification. This allows for communication over 10/100 Mbps Ethernet networks. The dual port hardware provides the user the choice of wiring in a star, line or ring configuration. For a ring configuration, device level ring (DLR) is available on this option card. This option has the ability to configure the IP Address from a user specified IP address, from a DHCP host, or from a BootP host. All parameters, diagnostics and operational commands are accessible via EtherNet/IP. Auto-tuning the motor is also possible through this option using the DriveWizard PC program. Mounts at option connector CN5-A.
SI-EM3D	Modbus TCP/IP – Dual Port	This option complies with the Modbus TCP/IP protocol specification. This allows for Modbus communication over 10/100 Mbps Ethernet networks. The dual port hardware provides the user the choice of wiring in a star, line or ring configuration. For a ring configuration, rapid spanning tree protocol (RSTP) is available on this option card. This option has the ability to configure the IP Address from a user specified IP address, from a DHCP host, or from a BootP host. All parameters, diagnostics and operational commands are accessible via Modbus TCP/ IP. Auto-tuning the motor is also possible through this option using the DriveWizard PC program. This option supports up to 10 simultaneous PLC/PC connections. Mounts at option connector CN5-A.

## Z1000U Matrix Drive Dimensions and Data

Table 119: 200 to 240 V

Rated Input Voltage	Model Number CIMR- ZU2E□□□□AUA	Units: mm (in)			Wt. kg (lb)	Drawing Number	Heat Loss (Watts)		
		H	W	D			Heatsink	Internal	Total
200 to 240 V 3-Phase	0028	480 (18.89)	250 (9.84)	360 (14.17)	21 (46)	DD.Z1KU.FR1.IP00	659	103	762
	0042	650 (25.60)	264 (10.39)	420 (16.53)	33 (73)	DD.Z1KU.FR2.IP00	854	168	1022
	0054				1037		195	1232	
	0068				1295		225	1520	
	0081	816 (32.12)	264 (10.39)	450 (17.71)	36 (79)	DD.Z1KU.FR3.IP00	1420	238	1658
	0104				1696		282	1978	
	0130	900 (38.97)	415 (16.33)	403 (15.86)	63 (139)	DD.Z1KU.FR4.IP00	2157	341	2498
	0154						2441	366	2807
	0192						3064	447	3511
	0248	1132 (44.56)	490 (19.29)	450 (17.71)	181 (399)	DD.Z1KU.FR4.5.IP00	3785	578	4363

Table 120: 380 to 480 V

Rated Input Voltage	Model Number CIMR- ZU4E□□□□AUA	Units: mm (in)			Wt. kg (lb)	Drawing Number	Heat Loss (Watts)		
		H	W	D			Heatsink	Internal	Total
380 to 480 V 3-Phase	0011	480 (18.89)	250 (9.84)	360 (14.17)	21 (46)	DD.Z1KU.FR1.IP00	452	80	532
	0014						459	79	538
	0021						641	105	746
	0027						675	106	781
	0034						798	124	922
	0040	650 (25.60)	264 (10.39)	420 (16.53)	33 (73)	DD.Z1KU.FR2.IP00	877	174	1051
	0052				1109		209	1318	
	0065				1369		240	1609	
	0077	816 (32.12)	264 (10.39)	450 (17.71)	36 (79)	DD.Z1KU.FR3.IP00	1479	251	1730
	0096				1715		290	2005	
	0124	990 (38.97)	415 (16.33)	403 (15.86)	63 (139)	DD.Z1KU.FR4.IP00	2256	362	2618
	0156						2857	421	3278
	0180						3316	482	3798
	0216	1132 (44.56)	490 (19.29)	450 (17.71)	181 (399)	DD.Z1KU.FR4.5.IP00	3720	587	4307
	0240						3897	600	4497
	0302	1132 (44.56)	695 (27.36)	450 (17.71)	267 (589)	DD.Z1KU.FR5.IP00	5202	857	6059
	0361						5434	863	6297
	0414						6444	1012	7456

# Z1000U Matrix Bypass Drive UL Type 1



The Z1000U MATRIX Bypass combines excellent harmonic mitigation, input power factor control, and energy saving capabilities in a design specifically suited for use in HVAC building automation applications that require reliable motor control.

The bypass package provides a Z1000U MATRIX drive in a UL Type 1 enclosure with input circuit breaker, and 2-contactor style bypass to allow motor operation from the drive or across the line. The Z1000U HVAC MATRIX drive incorporates MATRIX technology to directly convert input AC voltage to output AC voltage. The Z1000U HVAC MATRIX drive offers real choices and benefits for green HVAC applications.

The Z1000U features HVAC application-specific software macros, a Hand-Off-Auto LCD keypad, and a real-time clock for system accuracy. Popular building automation communication protocols BACnet (BTL certified), Siemens APOGEE FLN, Johnson Controls Metasys N2, and MEMOBUS/Modbus are embedded in the drive. Interface cards for LonWorks and EtherNet/IP communications are offered separately.

## Performance Features

- VT Ratings:
  - 208 VAC, 7.5 to 75 HP
  - 480 VAC, 7.5 to 350 HP
- V/f Control, Open Loop Vector Control for PM
- Overload capacity: 120% for 60 seconds
- 0-400 Hz Output Frequency
- DC Injection braking: at start or stop, adjustable, current limited (anti-windmilling)
- Adjustable Accel/Decel: 0.1 to 6000 seconds
- Controlled speed range: 40:1 (V/f)
- Critical frequency rejection capability: 3 selectable, adjustable bands
- Torque limiting: 0 to 300%
- Power loss ride-through: 2 seconds
- Auto restart after power loss or resettable fault, selectable, programmable
- Up/down floating point control capability
- Stationary motor auto-tuning
- 150% starting torque capability, available from 3 to 60 Hz
- Remote speed reference (speed command) signal:
  - 0 to 10 VDC/-10 to 10 VDC (20 K Ohms)
  - 4 to 20 mA/0 to 20 mADC (250 Ohms)

## Bypass Features

- Output and bypass contactors
- Lockable main input circuit breaker
- Thermal motor overload relay, class 20
- 115 VAC control transformer, fused
- Drive H/O/A keypad used for bypass control

- Damper control circuit with end of travel feedback and two adjustable wait time functions
- Selectable energy savings mode
- No load detection (loss of load) fully monitored in drive and bypass modes.

## Design Features

- Displacement power factor of 0.98 throughout the motor speed range
- NEC rated input / output amps
- Standard LCD Multi-lingual keypad, Full text, Hand-Off-Auto with Copy (Read/Write) Function
- Built-In real-time clock for time and date stamping events along with timer functions for starting, stopping and speed changes without the need for external controls
- Volt meter, ammeter, kilowatt meter elapsed run time meter and heat sink temperature monitoring functions
- Two internal (PID) Controls
- Drive internal PID closed-loop control with selectable engineering units
- Independent PID control for use with external device
- Differential PID feedback feature
- Sleep function in both closed-loop and open-loop control
- Feedback signal low pass filter
- Feedback signal loss detection and selectable response strategy
- Feedback signal inverse and square root capability
- Input and output terminal status indication
- Diagnostic fault indication
- VFD efficiency: 96% at half-speed; 98% at full-speed

- S-curve soft start / soft stop capability
- Serial communication loss detection and selectable response strategy
- Serial communication status
- Adjustable carrier frequency, 4 kHz to 10 kHz
- Programmable security code
- 8 programmable multi-function input terminals (24 VDC) providing 60+ programmable features, including:
  - BAS / Damper Interlock
  - Emergency Override
  - Preset Speed
  - PI control enable / disable
- 2x form A and 1x form C programmable multi-function output relays (Rated 1 amp @ 250 VAC & 30 VDC), providing 50+ functions, including:
  - Damper control
  - Hand/Auto Status
  - Customer Safeties
  - Contactor Control for External Bypass
  - Overtorque/undertorque detection
- One fixed, Fault, form C output relay (Rated 1 amp @ 250 VAC & 30 VDC)
- 6 preset speeds
- Built-in BACnet (BTL certified), Siemens APOGEE FLN, Johnson Controls Metasys N2, and MEMOBUS/Modbus communication
- Energy Savings Monitor
- Eco-Mode to achieve near across-the-line THD and quietest operation
- Flash upgradeable firmware
- Customizable monitor display
- Heat sink over temperature speed foldback feature
- Bumpless transfer between Hand and Auto
- Emergency override can be used as a Smoke Purge

- Fan failure detection and selectable drive action
- Built-in EMC Filter
- Built-in input fuses
- Input circuit breaker (100 kAIC)
- Compact Package
- Unity Power Factor Control
- <5% TDD Harmonic Characteristics
- Low Harmonics over Wide Speed Range
- DriveWizard HVAC Software
- Removable Terminal Block with Memory
- High Reliability with an MTBF of 28 Years
- Short Circuit Withstand Rating: 100K RMS

- Optimal Speed Command Search

### Service Conditions

- Input voltage: 208 VAC, 480 VAC, -15/+10%
- Input frequency: 50/60 Hz ±3% (Frequency fluctuation rate: 1 Hz/100 ms or less)
- Ambient service temperature: UL Type 1 (IP20):
  - -10 °C to 40 °C (14 °F to 104 °F)
- Maximum ambient storage temperature: -20 to 60 °C (-4 to 140 °F)
- Humidity: 0% to 95%, non-condensing
- Altitude: to 1000 meters (3300 feet); higher by derating

### Standards

- UL 508A (Industrial Control Panels)

### Options

- 2-Contactor Bypass
- Drive Service Switch
- 5% Output Reactor
- Soft-start Bypass
- Custom Nameplate
- Speed Pot (door mounted)
- 200 VA Control Power Transformer
- LonWorks Interface
- EtherNet/IP

## Catalog Code Configuration (Z1D1)

- 1) Complete the Base Number for the voltage and current rating.
- 2) Add the Option Code letter for each required option. If an option is not wanted, no character is inserted in that position.
- 3) Find the list price for the Base Number selected from the following pages. Add the list price of each selected option to this base price.

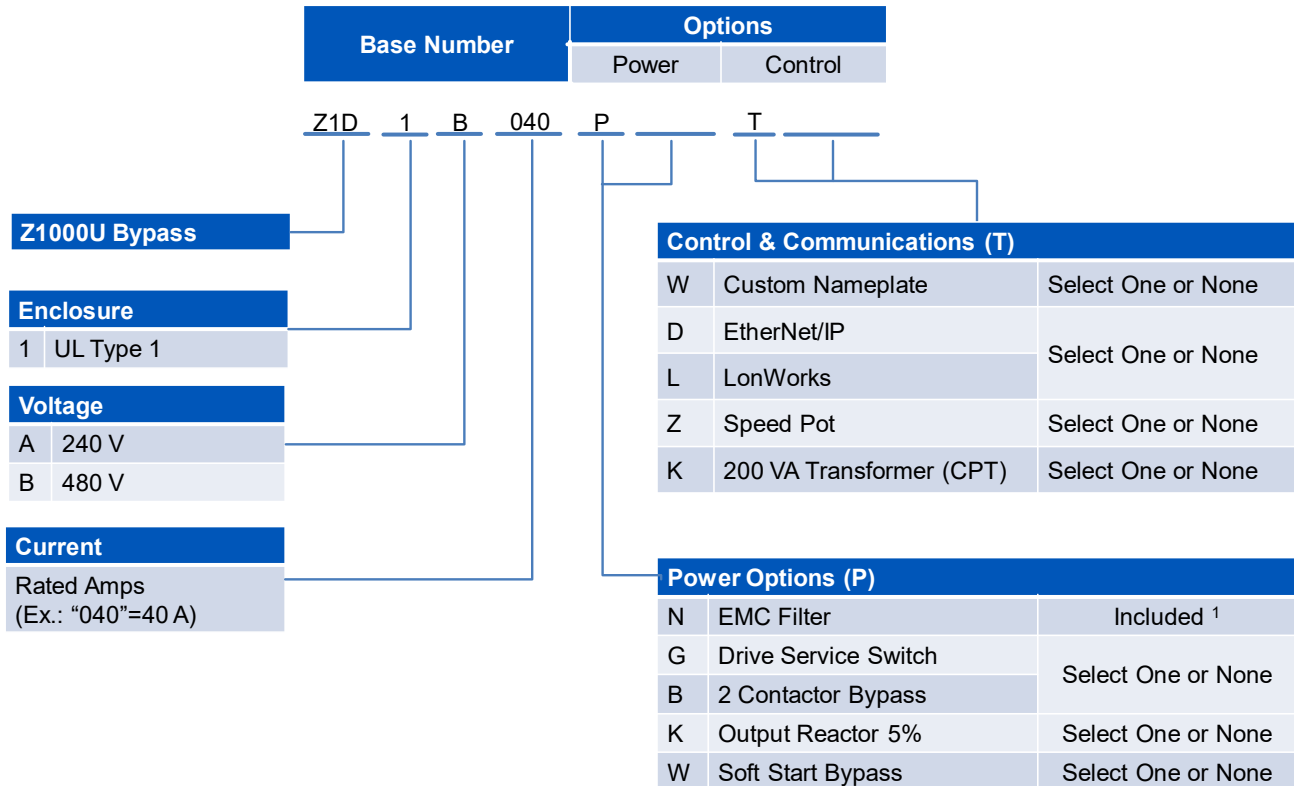

1 – An EMC Filter is internal to the Z1000U drive.

## Package Options (Z1D1)

Table 121: Enclosure Options

Option Code	Option	Description
1	UL Type 1	The drive and Configured options are provided in a UL Type 1 ventilated enclosure, large enough to accommodate any or all of the Configured package options.

Table 122: Power Options

Option Code	Option	Description
B	Drive Input Circuit	For a 2-contactor bypass that removes power from the drive, select option (B). Drive service switch that removes power from the drive, select option (G).
G		
K	Output Reactor	No form of output impedance is normally required. A 5% load reactor, option (K), is available if additional output impedance is desired (usually for long lead- lengths or noise reduction).
W	Soft Start Bypass <sup>1</sup>	Provides a solid-state adjustable soft starter for use when switching to bypass mode. Option (W) provides a solid-state soft-starter with adjustable ramp to reduce mechanical system stress typically associated with across-the-line bypass motor starts. Select option (W) if the application cannot tolerate the mechanical load stress caused by across-the-line bypass motor starts.

1. The following Z1D1 models have a short circuit withstand rating of 65 kA RMS symmetrical when option W is specified:

- Z1D1B011 to Z1D1B156

- Z1D1D024 to Z1D1D143

Other Z1D1 models have a short circuit withstand rating of 100 kA RMS symmetrical when option W is specified.

Table 123: Control Options

Option Code	Option	Description
D	EtherNet/IP (SI-EN3)	ODVA compliant option card to connect to EtherNet/IP.
L	LonWorks (SI-W3)	LonWorks, option (L), requires the addition of an optional board.
K	200 VA Transformer	200 VA Control Power Transformer (for customer use).
Z	Speed Pot	Door mounted.
W	Customer Nameplate	Custom engraved nameplates with white lettering on black lamacoid are available with option (W), for special tagging purposes, for example, AHU #1. Note that this option requires the text to be specified by the customer.

## Model and Power Option Section (Z1D1)

Table 124: 208 V Models and Power Options

Rated Input Voltage	Rated Output Current (Amps)	Nominal HP <sup>1</sup>	UL Type 1 MATRIX Bypass Drive (With EMC filter) <sup>2</sup>	Power Options				
				Soft Start Bypass	2 - Contactor Bypass	Drive Input Service Switch	Output Reactor	EMC Filter
			Z1D1. . . .	W	B	G	K	N <sup>2</sup>
208 V 3-Phase	24.2	7.5	D024PN	-		-		Included
	30.8	10	D030PN					
	46.2	15	D046PN					
	59.4	20	D059PN					
	74.8	25	D074PN					
	88	30	D088PN					
	114	40	D114PN					
	143	50	D143PN					
	169	60	D169PN					
211	75	D211PN						

1. Horsepower rating is based on standard NEMA B, 4-pole motor design as represented in NEC table 430.150 Full-Load Current, Three-Phase Alternating Current Motors at 208 volts.
2. An EMC filter is included, and is internal to the MATRIX drive.

Table 125: 480 V Model and Power Options

Rated Input Voltage	Rated Output Current (Amps)	Nominal HP <sup>1</sup>	UL Type 1 MATRIX Bypass Drive (With EMC filter) <sup>2</sup>	Power Options				
				Soft Start Bypass	2-Contactor Bypass	Drive Input Service Switch	Output Reactor	EMC Filter
			Z1D1. . . .	W	B	G	K	N <sup>2</sup>
480 V 3-Phase	11	7.5	B011PN	-		-		Included
	14	10	B014PN					
	21	15	B021PN					
	27	20	B027PN					
	34	25	B034PN					
	40	30	B040PN					
	52	40	B052PN					
	65	50	B065PN					
	77	60	B077PN					
	96	75	B096PN					
	124	100	B124PN					
	156	125	B156PN					
	180	150	B180PN					
	240	200	B240PN					
	302	250	B302PN					
	361	300	B361PN					
414	350	B414PN						

1. Horsepower rating is based on standard NEMA B, 4-pole motor design as represented in NEC table 430.150 Full-Load Current, Three-Phase Alternating Current Motors at 480 volts.
2. An EMC filter is included, and is internal to the MATRIX drive.



## Dimensions and Data (Z1D1)

Rated Input Voltage	Matrix Bypass Base No. Z1D1....	Rated Output Current (Amps)	Nominal HP <sup>1</sup>	Bypass Box No.	Submittal Documents (Outline Drawing) (Schematic)	Enclosed, UL Type 1 Bypass Data			
						Overall Dimensions (in)			Weight (lb)
						H	W	D	
208 V 3-Phase	D024	24.2	7.5	W1	DD.Z1U.1.W1.01 DS.Z1D1.01	48	22	18	230
	D030	30.8	10	W2	DD.Z1U.1.W2.01 DS.Z1D1.01	60	22	18	325
	D046	46.2	15						340
	D059	59.4	20						350
	D074	74.8	25						350
	D088	88	30	W3	DD.Z1U.1.W3.01 DS.Z1D1.01	60	30	20	465
	D114	114	40						475
	D143	143	50	F1	DD.Z1U.1.F1.01 DS.Z1D1.01	86	41	32	825
	D169	169	60						825
D211	211	75	1050						
480 V 3-Phase	B011	11	7.5	W1	DD.Z1U.1.W1.01 DS.Z1D1.01	48	22	18	220
	B014	14	10						230
	B021	21	15						230
	B027	27	20	W2	DD.Z1U.1.W2.01 DS.Z1D1.01	60	22	18	300
	B034	34	25						300
	B040	40	30						315
	B052	52	40						350
	B065	65	50						360
	B077	77	60						375
	B096	96	75	W3	DD.Z1U.1.W3.01 DS.Z1D1.01	60	30	20	475
	B124	124	100						490
	B156	156	125	F1	DD.Z1U.1.F1.01 DS.Z1D1.01	86	41	32	850
	B180	180	150						900
	B240	240	200						1,100
	B302	302	250	F2	DD.Z1U.1.F2.01 DS.Z1D1.01	86	70	31	1,600
	B361	361	300						1,750
B414	414	350	1,800						

1. Horsepower rating is based on standard NEMA B, 4-pole motor design as represented in NEC table 430.150 Full-Load Current, Three-Phase Alternating Current Motors.

## Z1000U Matrix Bypass Drive UL Type 3R



The Z1000U MATRIX Bypass combines excellent harmonic mitigation, input power factor control, and energy saving capabilities in a design specifically suited for use in HVAC building automation applications that require reliable motor control.

The bypass package provides a Z1000U MATRIX drive in a UL Type 3R enclosure with input circuit breaker, and 3 - contactor style bypass to allow motor operation from the drive or across the line. The Z1000U HVAC MATRIX drive incorporates MATRIX technology to directly convert input AC voltage to output AC voltage. The Z1000U HVAC MATRIX drive offers real choices and benefits for green HVAC applications.

The Z1000U features HVAC application-specific software macros, a Hand-Off-Auto LCD keypad, and a real-time clock for system accuracy. Popular building automation communication protocols BACnet (BTL certified), Siemens APOGEE FLN, Johnson Controls Metasys N2, and MEMOBUS/Modbus are embedded in the drive. Interface cards for LonWorks and EtherNet/IP communications are offered separately.

### Performance Features

- VT Ratings:
  - 208 VAC, 7.5 to 75 HP
  - 480 VAC, 7.5 to 350 HP
- V/f Control, Open Loop Vector Control for PM
- Overload capacity: 120% for 60 seconds
- 0-400 Hz Output Frequency
- DC Injection braking: at start or stop, adjustable, current limited (anti-windmilling)
- Adjustable Accel/Decel: 0.1 to 6000 seconds
- Controlled speed range: 40:1 (V/f)
- Critical frequency rejection capability: 3 selectable, adjustable bands
- Torque limiting: 0 to 300%
- Power loss ride-through: 2 seconds
- Auto restart after power loss or resettable fault, selectable, programmable
- Up/down floating point control capability
- Stationary motor auto-tuning
- 150% starting torque capability, available from 3 to 60 Hz
- Remote speed reference (speed command) signal:
  - 0 to 10 VDC/-10 to 10 VDC (20 K Ohms)
  - 4 to 20 mA/0 to 20 mADC (250 Ohms)

### Bypass Features

- Output and bypass contactors
- Lockable main input circuit breaker
- Thermal motor overload relay, class 20
- 115 VAC control transformer, fused
- Drive H/O/A keypad used for bypass control

- Damper control circuit with end of travel feedback and two adjustable wait time functions
- Selectable energy savings mode
- No load detection (loss of load) fully monitored in drive and bypass modes.

### Design Features

- Displacement power factor of 0.98 throughout the motor speed range
- NEC rated input / output amps
- Standard LCD Multi-lingual keypad, Full text, Hand-Off-Auto with Copy (Read/Write) Function
- Built-In real-time clock for time and date stamping events along with timer functions for starting, stopping and speed changes without the need for external controls
- Volt meter, ammeter, kilowatt meter elapsed run time meter and heat sink temperature monitoring functions
- Two internal (PID) Controls
- Drive internal PID closed-loop control with selectable engineering units
- Independent PID control for use with external device
- Differential PID feedback feature
- Sleep function in both closed-loop and open-loop control
- Feedback signal low pass filter
- Feedback signal loss detection and selectable response strategy
- Feedback signal inverse and square root capability
- Input and output terminal status indication
- Diagnostic fault indication
- VFD efficiency: 96% at half-speed; 98% at full-speed

- S-curve soft start / soft stop capability
- Serial communication loss detection and selectable response strategy
- Serial communication status
- Adjustable carrier frequency, 4 kHz to 10 kHz
- Programmable security code
- 8 programmable multi-function input terminals (24 VDC) providing 60+ programmable features, including:
  - BAS / Damper Interlock
  - Emergency Override
  - Preset Speed
  - PI control enable / disable
- 2x form A and 1x form C programmable multi-function output relays (Rated 1 amp @ 250 VAC & 30 VDC), providing 50+ functions, including:
  - Damper control
  - Hand/Auto Status
  - Customer Safeties
  - Contactor Control for External Bypass
  - Overtorque/undertorque detection
- One fixed, Fault, form C output relay (Rated 1 amp @ 250 VAC & 30 VDC)
- 6 preset speeds
- Built-in BACnet (BTL certified), Siemens APOGEE FLN, Johnson Controls Metasys N2, and MEMOBUS/Modbus communication
- Energy Savings Monitor
- Eco-Mode to achieve near across-the-line THD and quietest operation
- Flash upgradeable firmware
- Customizable monitor display
- Heat sink over temperature speed foldback feature
- Bumpless transfer between Hand and Auto

- Emergency Override can be used as a Smoke Purge
- Fan failure detection and selectable drive action
- Built-in EMC Filter
- Built-in input fuses
- Input circuit breaker (100 kAIC)
- Compact Package
- Unity Power Factor Control
- <5% TDD Harmonic Characteristics
- Low Harmonics over Wide Speed Range
- DriveWizard HVAC Software
- Removable Terminal Block with Memory
- High Reliability with an MTBF of 28 Years
- Short Circuit Withstand Rating: 100K RMS

- Optimal Speed Command Search

### Service Conditions

- Input voltage: 208 VAC, 480 VAC, -15/+10%
- Input frequency: 50/60 Hz ±3% (Frequency fluctuation rate: 1 Hz/100 ms or less)
- Ambient service temperature: UL Type 3R:
  - -10 °C to 40 °C (14 °F to 104 °F)
- Maximum ambient storage temperature: -20 to 60 °C (-4 to 140 °F)
- Humidity: 0% to 95%, non-condensing
- Altitude: to 1000 meters (3300 feet)

### Standards

- UL 508A (Industrial Control Panels)

### Options

- 3-Contactor Bypass
- Drive Service Switch (40°C Rated)
- 5% Output Reactor
- Soft-start Bypass
- Custom Nameplate
- Speed Pot (door mounted)
- 200 VA Control Power Transformer
- LonWorks Interface
- EtherNet/IP
- Keypad Viewing Window
- Space Heater

## Catalog Code Configuration (Z1D3)

- 1) Complete the Base Number for the voltage and current rating.
- 2) Add the Option Code letter for each required option. If an option is not wanted, no character is inserted in that position.
- 3) Find the list price for the Base Number selected from the following pages. Add the list price of each selected option to this base price.

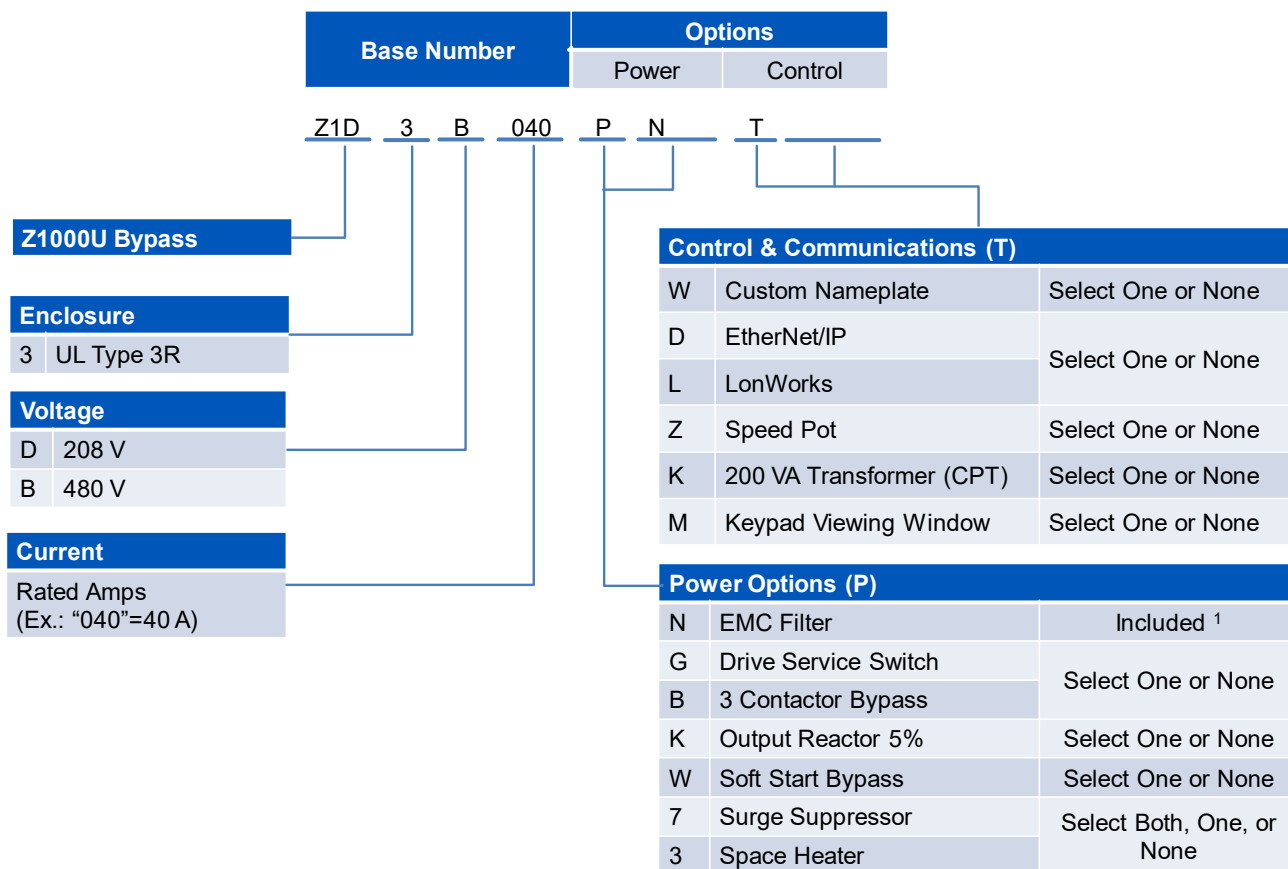

<sup>1</sup> – An EMC Filter is internal to the Z1000U drive.

## Package Options (Z1D3)

Table 126: Enclosure Options

Option Code	Option	Description
3	UL Type 3R	The drive and configured options are provided in a UL Type 3R ventilated enclosure, large enough to accommodate any or all of the Configured package options.

Table 127: Power Options

Option Code	Option	Description
B	Drive Input Circuit	For a 3-contactor bypass that removes power from the drive, select option (B). Drive service switch that removes power from the drive, select option (G).
G		
K	Output Reactor	No form of output impedance is normally required. A 5% load reactor, option (K), is available if additional output impedance is desired (usually for long lead- lengths or noise reduction).
W	Soft Start Bypass	Provides a solid-state adjustable soft starter for use when switching to bypass mode. Option (W) provides a solid-state soft-starter with adjustable ramp to reduce mechanical system stress typically associated with across-the-line bypass motor starts. Select option (W) if the application cannot tolerate the mechanical load stress caused by across-the-line bypass motor starts. The following Z1D1 models have a short circuit withstand rating of 65 kA RMS symmetrical when option W is specified: - Z1D3B011 to Z1D3B156 and - Z1D3D024 to Z1D3D143 Other Z1D1 models have a short circuit withstand rating of 100 kA RMS symmetrical when option W is specified.
7	Surge Suppressor	This option provides a degree of protection from transient surges coming through the power line cables. Lightning strikes are the most common source of surges.
3	Space Heater	This option helps reduce condensation.

Table 128: Control Options

Option Code	Option	Description
D	EtherNet/IP (SI-EN3)	ODVA compliant option card to connect to EtherNet/IP.
L	LonWorks (SI-W3)	LonWorks, option (L), requires the addition of an optional board.
M	Keypad Viewing Window	The digital drive keypad is mounted on the outside of the UL Type 3R enclosure door. This option provides a viewing window that is hinged and lockable.
K	200 VA Transformer	200 VA Control Power Transformer (for customer use).
Z	Speed Pot	Door mounted.
W	Customer Nameplate	Custom engraved nameplates with white lettering on black lamicoide are available with option (W), for special tagging purposes, for example, AHU #1. Note that this option requires the text to be specified by the customer.

Table 129: Freestanding Leg Kits

Catalog Code	Description
UUX001158	12 in. Leg Kit: This option allows the UL Type 3R wall-mount enclosures to be mounted on legs so that the control can be freestanding and off the ground. Either kit can be used on any of the wall-mount enclosures. Floor-mount enclosures come standard with freestanding legs. <sup>1</sup>
UUX001159	30 in. Leg Kit: This option allows the NEMA 3R wall-mount enclosures to be mounted on legs so that the control can be freestanding and off the ground. Either kit can be used on any of the wall-mount enclosures. Floor-mount enclosures come standard with freestanding legs. <sup>1</sup>

1. Leg kits are designed to be installed in the field.

## Model and Power Options (Z1D3)

Table 130: 208 V Models and Power Options

Rated Input Voltage	Rated Output Current (Amps)	Nominal HP <sup>1</sup>	NEMA 3R MATRIX Bypass Drive (With EMC filter) <sup>2</sup>	Power Options						
				Soft Start Bypass	3-Contactor Bypass	Drive Input Service Switch	Output Reactor	EMC Filter	Surge Suppressor	Space Heater
				Z1D3	W	B	G	K	N <sup>2</sup>	7
208 V 3-Phase	24.2	7.5	D024PN	-	-	-	-	Included	-	-
	30.8	10	D030PN							
	46.2	15	D046PN							
	59.4	20	D059PN							
	74.8	25	D074PN							
	88	30	D088PN							
	114	40	D114PN							
	143	50	D143PN							
	169	60	D169PN							
	211	75	D211PN							

- Horsepower rating is based on standard NEMA B, 4-pole motor design as represented in NEC table 430.150 Full-Load Current, Three-Phase Alternating Current Motors at 208 volts.
- An EMC filter is included, and is internal to the MATRIX drive.

Table 131: 480 V Model and Power Options

Rated Input Voltage	Rated Output Current (Amps)	Nominal HP <sup>1</sup>	NEMA 3R MATRIX Bypass Drive (With EMC filter) <sup>2</sup>	Power Options						
				Soft Start Bypass	3-Contactor Bypass	Drive Input Service Switch	Output Reactor	EMC Filter	Surge Suppressor	Space Heater
				Z1D3	W	B	G	K	N <sup>2</sup>	7
480 V 3-Phase	11	7.5	B011PN	-	-	-	-	Included	-	-
	14	10	B014PN							
	21	15	B021PN							
	27	20	B027PN							
	34	25	B034PN							
	40	30	B040PN							
	52	40	B052PN							
	65	50	B065PN							
	77	60	B077PN							
	96	75	B096PN							
	124	100	B124PN							
	156	125	B156PN							
	180	150	B180PN							
	240	200	B240PN							
	302	250	B302PN							
	361	300	B361PN							
414	350	B414PN								

1. Horsepower rating is based on standard NEMA B, 4-pole motor design as represented in NEC table 430.150 Full-Load Current, Three-Phase Alternating Current Motors at 480 volts.
2. An EMC filter is included, and is internal to the MATRIX drive.

## Dimensions and Data (Z1D3)

Refer to the product page on the Yaskawa website for dimension, weight, and schematic diagram data depending on drive model and installed options.

Use document [PD.Z1000.01](#) for 208 V models.

Use document [PD.Z1000.02](#) for 480 V models

# Z1000U Matrix Configured Drive UL Type 1



The Z1000U Configured variable-speed MATRIX drive combines excellent harmonic mitigation, input power factor control, and energy saving capabilities in a design allowing flexibility when providing the features and options commonly specified by facility designers.

The configured package provides a Z1000U MATRIX drive containing HVAC application-specific software macros, a real-time clock, and Hand-Off-Auto LCD keypad with an input disconnect switch and space for several power options inside a NEMA 1 (UL Type 1) enclosure.

The Z1000U HVAC MATRIX drive incorporates MATRIX technology to directly convert input AC voltage to output AC voltage. The Z1000U HVAC MATRIX drive offers real choices and benefits for green HVAC applications.

Popular building automation communication protocols BACnet (BTL certified), Siemens APOGEE FLN, Johnson Controls Metasys N2, and MEMOBUS/Modbus are embedded in the drive. Interface cards for LonWorks and EtherNet/IP communications are offered separately.

## Performance Features

- VT Ratings:
  - 208 VAC, 7.5 to 75 HP
  - 480 VAC, 7.5 to 350 HP
- V/f Control, Open Loop Vector Control for PM
- Overload capacity: 120% for 60 seconds
- 0-400 Hz Output Frequency
- DC Injection braking: at start or stop, adjustable, current limited (anti-windmilling)
- Adjustable Accel/Decel: 0.1 to 6000 seconds
- Controlled speed range: 40:1 (V/f)
- Critical frequency rejection capability: 3 selectable, adjustable bands
- Torque limiting: 0 to 300%
- Power loss ride-through: 2 seconds
- Auto restart after power loss or resettable fault, selectable, programmable
- Up/down floating point control capability
- Stationary motor auto-tuning

## Design Features

- Displacement power factor of 0.98 throughout the motor speed range
- NEC rated input / output amps
- Standard LCD Multi-lingual keypad, Full-text, Hand-Off-Auto with Copy (Read/Write) Function
- Built-In real-time clock for time and date stamping events along with timer functions for starting, stopping and speed changes without the need for external controls
- Volt meter, ammeter, kilowatt meter elapsed run time meter and heat sink temperature monitoring functions
- Two internal (PID) Controls

- Drive internal PID closed-loop control with selectable engineering units
- Independent PID control for use with external device
- Differential PID feedback feature
- Sleep function in both closed-loop and open-loop control
- Feedback signal low pass filter
- Feedback signal loss detection and selectable response strategy
- Feedback signal inverse and square root capability
- Input and output terminal status indication
- Diagnostic fault indication
- VFD efficiency: 96% at half-speed; 98% at full-speed
- S-curve soft start / soft stop capability
- Serial communication loss detection and selectable response strategy
- 150% starting torque capability, available from 3 Hz
- Remote speed reference (speed command) signal:
  - 0 to 10 VDC/-10 to 10 VDC (20 K Ohms)
  - 4 to 20 mA/0 to 20 mA DC (250 Ohms)
- Adjustable carrier frequency, 4 kHz to 10 kHz
- Programmable security code
- 8 programmable multi-function input terminals (24 VDC) providing 60+ programmable features, including:
  - BAS / Damper Interlock
  - Emergency Override
  - Preset Speed
  - PI control enable / disable
- 2x form A and 1x form C programmable multi-function output relays (Rated 1 amp @ 250

VAC & 30 VDC), providing 50+ functions, including:

- Damper control
- Hand/Auto Status
- Customer Safeties
- Contactor Control for External Bypass
- Overtorque/undertorque detection
- Serial communication status
- No load detection
- One fixed, Fault, form C output relay (Rated 1 amp @ 250 VAC & 30 VDC)
- 6 preset speeds
- Built-in BACnet (BTL certified), Siemens APOGEE FLN, Johnson Controls Metasys N2, and MEMOBUS/Modbus communication
- Energy Savings Monitor
- Eco-Mode to achieve near across-the-line THD and quietest operation
- Flash upgradeable firmware
- Customizable monitor display
- Heat sink over temperature speed foldback feature
- Bumpless transfer between Hand and Auto
- Emergency override can be used as a Smoke Purge
- Fan failure detection and selectable drive action
- Built-in EMC Filter
- Built-in input fuses
- Input disconnect switch
- Energy Savings - Low Power Loss Design
- Compact Package
- Unity Power Factor Control
- <5% TDD Harmonic Characteristics

- Low Harmonics over Wide Speed Range
- DriveWizard HVAC Software
- Removable Terminal Block with Memory
- High Reliability with an MTBF of 28 Years
- Short Circuit Withstand Rating: 100K RMS
- Optimal Speed Command Search

- Ambient service temperature: NEMA 1 (IP20):
  - -10 °C to 40 °C (14 °F to 104 °F)
- Maximum ambient storage temperature: -20 to 60 °C (-4 to 140 °F)
- Humidity: 0% to 95%, non-condensing
- Altitude: to 1000 meters (3300 feet); higher by derating
- Service factor: 1.0

### Options

- 5% Output Reactor
- Lockable input circuit breaker (100 kAIC)
- Custom Nameplate
- Speed Pot (door mounted)
- 200 VA Control Power Transformer
- LonWorks Interface
- EtherNet/IP

### Service Conditions

- Input voltage: 208 VAC, 480 VAC, -15/+10 %
- Input frequency: 50/60 Hz ±3% (Frequency fluctuation rate: 1 Hz/100 ms or less)

### Standards

- UL 508A (Industrial Control Panels)

## Catalog Code Configuration (Z1E1)

- 1) Complete the Base Number for the voltage and current rating.
- 2) Add the Option Code letter for each required option. If an option is not wanted, no character is inserted in that position.
- 3) Find the list price for the Base Number selected from the following pages. Add the list price of each selected option to this base price.

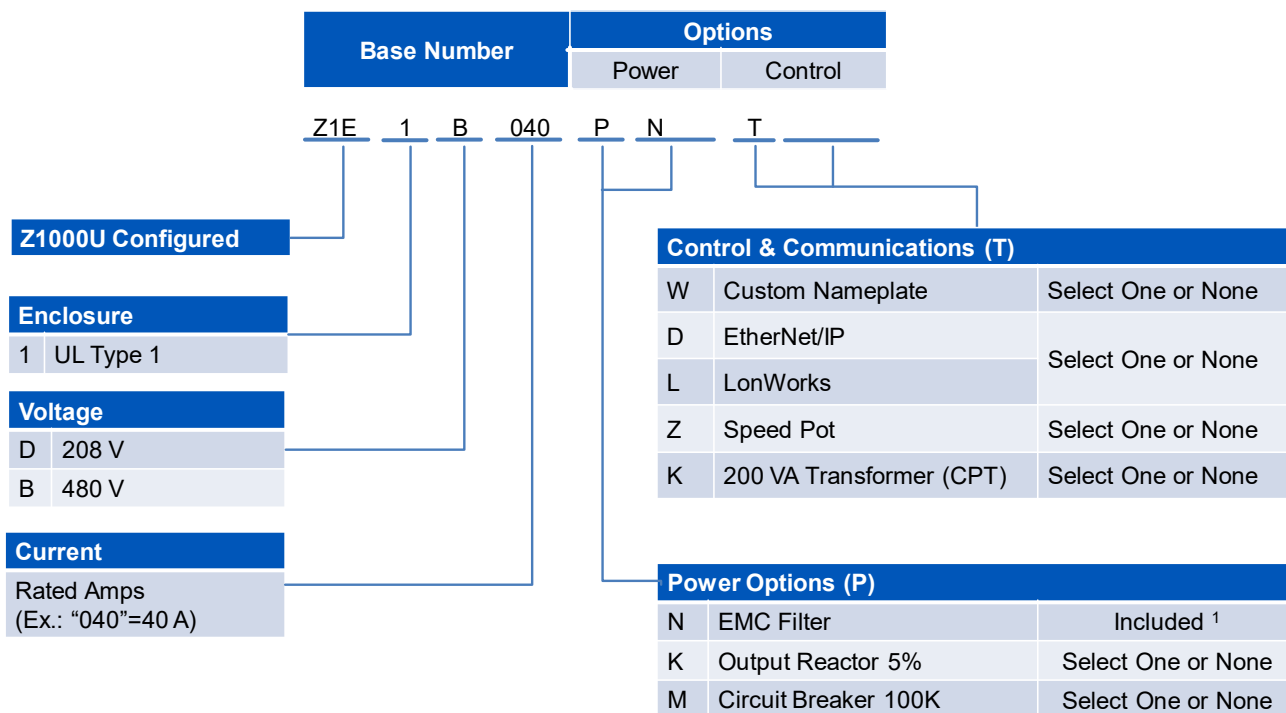

1 – An EMC Filter is internal to the Z1000U drive.



## Package Options (Z1E1)

Table 132: Power Options

Option Code	Option	Description
K	Output Reactor	No form of output impedance is normally required. A 5% load reactor, option (K), is available if additional output impedance is desired (usually for long lead-lengths or noise reduction).
M	Circuit Breaker 100 kAIC	Lockable input Circuit Breaker (100 kAIC panel rating)

Table 133: Control Options

Option Code	Option	Description
D	EtherNet/IP (SI-EN3)	ODVA compliant option card to connect to EtherNet/IP.
L	LonWorks (SI-W3)	LonWorks, option (L), requires the addition of an optional board.
K	200 VA Transformer	200 VA Control Power Transformer (for customer use).
Z	Speed Pot	Door mounted.
W	Customer Nameplate	Custom engraved nameplates with white lettering on black lamicaid are available with option (W), for special tagging purposes, for example, AHU #1. Note that this option requires the text to be specified by the customer.

## Model and Power Option Selection

Table 134: 208 V Models and Power Options

Rated Input Voltage	Rated Output Current (Amps)	Nominal HP <sup>1</sup>	NEMA 1 Configured Matrix (With EMC filter) <sup>2</sup>	Power Options		
				Circuit Breaker (100 kAIC)	Output Reactor	EMC Filter
			Z1E1...xx	M	K	N <sup>2</sup>
208 V 3-Phase	24.2	7.5	D024PN	-	K	Included
	30.8	10	D030PN			
	46.2	15	D046PN			
	59.4	20	D059PN			
	74.8	25	D074PN			
	88	30	D088PN			
	114	40	D114PN			
	143	50	D143PN			
	169	60	D169PN			
211	75	D211PN				

- Horsepower rating is based on standard NEMA B, 4-pole motor design as represented in NEC table 430.150 Full-Load Current, Three-Phase Alternating Current Motors at 208 volts.
- An EMC filter is included, and is internal to the MATRIX drive.

Table 135: 480 V Models and Power Options

Rated Input Voltage	Rated Output Current (Amps)	Nominal HP <sup>1</sup>	NEMA 1 Configured Matrix (With EMC filter) <sup>2</sup>	Power Options		
			Z1E1. . . . xx	Circuit Breaker (100 kAIC)	Output Reactor	EMC Filter
				M	K	N <sup>2</sup>
480 V 3-Phase	11	7.5	B011PN	-		Included
	14	10	B014PN			
	21	15	B021PN			
	27	20	B027PN			
	34	25	B034PN			
	40	30	B040PN			
	52	40	B052PN			
	65	50	B065PN			
	77	60	B077PN			
	96	75	B096PN			
	124	100	B124PN			
	156	125	B156PN			
	180	150	B180PN			
	240	200	B240PN			
	302	250	B302PN			
	361	300	B361PN			
414	350	B414PN				

- Horsepower rating is based on standard NEMA B, 4-pole motor design as represented in NEC table 430.150 Full-Load Current, Three-Phase Alternating Current Motors at 480 volts.
- An EMC filter is included, and is internal to the MATRIX drive.

## Dimensions and Data (Z1E1)

Rated Input Voltage	Matrix Configured Base No. Z1E1. . . .	Rated Output Current (Amps)	Nominal HP <sup>1</sup>	Bypass Box No.	Submittal Documents (Outline Drawing) (Schematic)	Enclosed, NEMA 1 Configured Data			
						Overall Dimensions (in)			Weight (lb)
						H	W	D	
208 V 3-Phase	D024	24.2	7.5	W1	DD.Z1U.1.W1.01 DS.Z1E1.01	48	22	18	210
	D030	30.8	10	W2	DD.Z1U.1.W2.01 DS.Z1E1.01	60	22	18	300
	D046	46.2	15						305
	D059	59.4	20						315
	D074	74.8	25	W3	DD.Z1U.1.W3.01 DS.Z1E1.01	60	30	20	315
	D088	88	30						420
	D114	114	40	F1	DD.Z1U.1.F1.01 DS.Z1E1.01	86	41	32	430
	D143	143	50						745
	D169	169	60						745
D211	211	75	945						

Rated Input Voltage	Matrix Configured Base No. Z1E1. . . .	Rated Output Current (Amps)	Nominal HP <sup>1</sup>	Bypass Box No.	Submittal Documents (Outline Drawing) (Schematic)	Enclosed, NEMA 1 Configured Data			
						Overall Dimensions (in)			Weight (lb)
						H	W	D	
480 V 3-Phase	B011	11	7.5	W1	DD.Z1U.1.W1.01 DS.Z1E1.01	48	22	18	200
	B014	14	10						210
	B021	21	15						210
	B027	27	20	W2	DD.Z1U.1.W2.01 DS.Z1E1.01	60	22	18	270
	B034	34	25						270
	B040	40	30						285
	B052	52	40						315
	B065	65	50						325
	B077	77	60						340
	B096	96	75	W3	DD.Z1U.1.W3.01 DS.Z1E1.01	60	30	20	425
	B124	124	100						440
	B156	156	125	F1	DD.Z1U.1.F1.01 DS.Z1E1.01	86	41	32	765
	B180	180	150						810
	B240	240	200						990
	B302	302	250	F2	DD.Z1U.1.F2.01 DS.Z1E1.01	86	70	31	1,440
	B361	361	300						1,575
B414	414	350	1,620						

1. Horsepower rating is based on standard NEMA B, 4-pole motor design as represented in NEC table 430.150 Full-Load Current, Three-Phase Alternating Current Motors.

## Z1000U Matrix Configured Drive UL Type 3R



The Z1000U Configured variable-speed MATRIX drive combines excellent harmonic mitigation, input power factor control, and energy saving capabilities in a design allowing flexibility when providing the features and options commonly specified by facility designers.

The configured package provides a Z1000U MATRIX drive containing HVAC application-specific software macros, a real-time clock, and Hand-Off-Auto LCD keypad with an input disconnect switch and space for several power options inside a NEMA 3R (UL Type 3R) enclosure.

The Z1000U HVAC MATRIX drive incorporates MATRIX technology to directly convert input AC voltage to output AC voltage. The Z1000U HVAC MATRIX drive offers real choices and benefits for green HVAC applications.

Popular building automation communication protocols BACnet (BTL certified), Siemens APOGEE FLN, Johnson Controls Metasys N2, and MEMOBUS/Modbus are embedded in the drive. Interface cards for LonWorks and EtherNet/IP communications are offered separately.

### Performance Features

- VT Ratings:
  - 208 VAC, 7.5 to 75 HP
  - 480 VAC, 7.5 to 350 HP
- V/f Control, Open Loop Vector Control for PM
- Overload capacity: 120% for 60 seconds
- 0-400 Hz Output Frequency
- DC Injection braking: at start or stop, adjustable, current limited (anti-windmilling)
- Adjustable Accel/Decel: 0.1 to 6000 seconds
- Controlled speed range: 40:1 (V/f)
- Critical frequency rejection capability: 3 selectable, adjustable bands
- Torque limiting: 0 to 300%
- Power loss ride-through: 2 seconds
- Auto restart after power loss or resettable fault, selectable, programmable
- Up/down floating point control capability
- Stationary motor auto-tuning

### Design Features

- Displacement power factor of 0.98 throughout the motor speed range
- NEC rated input / output amps
- Standard LCD Multi-lingual keypad, Full-text, Hand-Off-Auto with Copy (Read/Write) Function
- Built-In real-time clock for time and date stamping events along with timer functions for starting, stopping and speed changes without the need for external controls
- Volt meter, ammeter, kilowatt meter elapsed run time meter and heat sink temperature monitoring functions
- Two internal (PID) Controls

- Drive internal PID closed-loop control with selectable engineering units
- Independent PID control for use with external device
- Differential PID feedback feature
- Sleep function in both closed-loop and open-loop control
- Feedback signal low pass filter
- Feedback signal loss detection and selectable response strategy
- Feedback signal inverse and square root capability
- Input and output terminal status indication
- Diagnostic fault indication
- VFD efficiency: 96% at half-speed; 98% at full-speed
- S-curve soft start / soft stop capability
- Serial communication loss detection and selectable response strategy
- 150% starting torque capability, available from 3 Hz
- Remote speed reference (speed command) signal:
  - 0 to 10 VDC/-10 to 10 VDC (20 K Ohms)
  - 4 to 20 mA/0 to 20 mADC (250 Ohms)
- Adjustable carrier frequency, 4 kHz to 10 kHz
- Programmable security code
- 8 programmable multi-function input terminals (24 VDC) providing 60+ programmable features, including:
  - BAS / Damper Interlock
  - Emergency Override
  - Preset Speed
  - PI control enable / disable
- 2x form A and 1x form C programmable multi-function output relays (Rated 1 amp @ 250

VAC & 30 VDC), providing 50+ functions, including:

- Damper control
- Hand/Auto Status
- Customer Safeties
- Contactor Control for External Bypass
- Overtorque/undertorque detection
- Serial communication status
- No load detection (broken belt alert)
- One fixed, Fault, form C output relay (Rated 1 amp @ 250 VAC & 30 VDC)
- 6 preset speeds
- Built-in BACnet (BTL certified), Siemens APOGEE FLN, Johnson Controls Metasys N2, and MEMOBUS/Modbus communication
- Energy Savings Monitor
- Eco-Mode to achieve near across-the-line THD and quietest operation
- Flash upgradeable firmware
- Customizable monitor display
- Heat sink over temperature speed foldback feature
- Bumpless™ transfer between Hand and Auto
- Emergency override can be used as smoke purge™
- Fan failure detection and selectable drive action
- Built-in EMC Filter
- Built-in input fuses
- Input disconnect switch
- Energy Savings - Low Power Loss Design
- Compact Package
- Unity Power Factor Control
- <5% TDD Harmonic Characteristics

- Low Harmonics over Wide Speed Range
- DriveWizard HVAC Software
- Removable Terminal Block with Memory
- High Reliability with an MTBF of 28 Years
- Short Circuit Withstand Rating: 100K RMS
- Optimal Speed Command Search

- -10 °C to 40 °C (14 °F to 104 °F)
- Maximum ambient storage temperature: -20 to 60 °C (-4 to 140 °F)
- Humidity: 0% to 95%, non-condensing
- Altitude: to 1000 meters (3300 feet); higher by derating
- Service factor: 1.0

- Lockable input circuit breaker (100 kAIC)
- Custom Nameplate
- Speed Pot (door mounted)
- 200 VA Control Power Transformer
- LonWorks Interface
- EtherNet/IP
- Keypad Viewing Window
- Surge Suppressor
- Space Heater

**Service Conditions**

- Input voltage: 208 VAC, 480 VAC, -15/+10%
- Input frequency: 50/60 Hz ±3% (Frequency fluctuation rate: 1 Hz/100 ms or less)
- Ambient service temperature: NEMA 3R:

**Standards**

- UL 508A (Industrial Control Panels)

**Options**

- 5% Output Reactor

## Catalog Code Configuration (Z1E3)

- 1) Complete the Base Number for the voltage and current rating.
- 2) Add the Option Code letter for each required option. If an option is not wanted, no character is inserted in that position.
- 3) Find the list price for the Base Number selected from the following pages. Add the list price of each selected option to this base price.

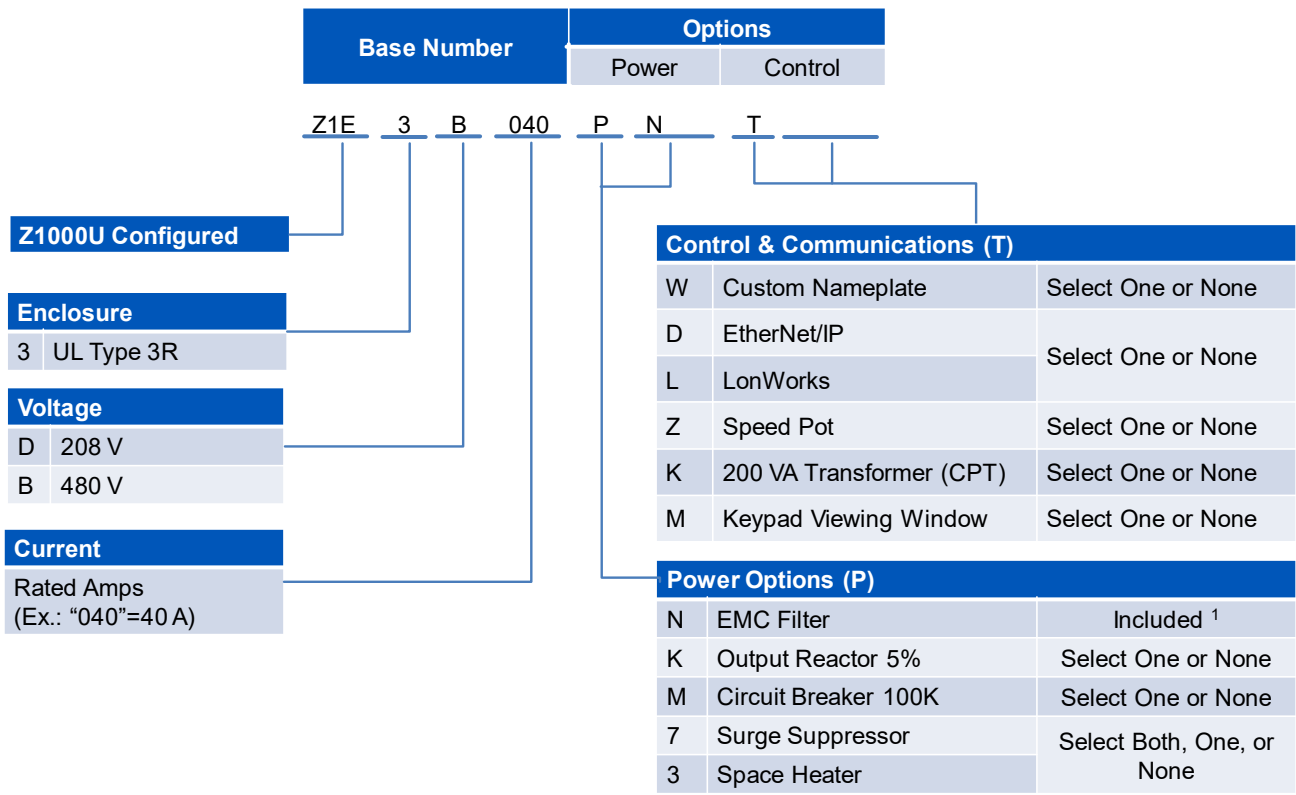

1 – An EMC Filter is internal to the Z1000U drive.

## Package Options (Z1E3)

Table 136: Enclosure Options

Option Code	Option	Description
3	NEMA 3R	The drive and configured options are provided in a NEMA Type 3R ventilated enclosure, large enough to accommodate any or all of the Configured package options.

Table 137: Power Options

Option Code	Option	Description
K	Output Reactor	No form of output impedance is normally required. A 5% load reactor, option (K), is available if additional output impedance is desired (usually for long lead- lengths or noise reduction).
M	Circuit Breaker 100 kAIC	Lockable input Circuit Breaker (100 kAIC panel rating)
7	Surge Suppressor	This option provides a degree of protection from transient surges coming through the power line cables. Lightning strikes are the most common source of surges.
3	Space Heater	This option helps reduce condensation.

Table 138: Control Options

Option Code	Option	Description
D	EtherNet/IP (SI-EN3)	ODVA compliant option card to connect to EtherNet/IP.
L	LonWorks (SI-W3)	LonWorks, option (L), requires the addition of an optional board.
M	Keypad Viewing Window	The digital drive keypad is mounted on the outside of the NEMA 3R enclosure door. This option provides a viewing window that is hinged and lockable.
K	200 VA Transformer	200 VA Control Power Transformer (for customer use).
Z	Speed Pot	Door mounted.
W	Customer Nameplate	Custom engraved nameplates with white lettering on black lamicaid are available with option (W), for special tagging purposes (Example: AHU #1"). Note that this option requires the text to be specified by the customer.

Table 139: Freestanding Leg Kits

Catalog Code	Description
UUX001158	12 in. Leg Kit: This option allows the NEMA 3R wall-mount enclosures to be mounted on legs so that the control can be freestanding and off the ground. Either kit can be used on any of the wall-mount enclosures. Floor-mount enclosures come standard with freestanding legs. <sup>1</sup>
UUX001159	30 in. Leg Kit: This option allows the NEMA 3R wall-mount enclosures to be mounted on legs so that the control can be freestanding and off the ground. Either kit can be used on any of the wall-mount enclosures. Floor-mount enclosures come standard with freestanding legs. <sup>1</sup>

1. Leg kits are designed to be installed in the field.

## Model and Power Option Selection (Z1E3)

Table 140: 208 V Models and Power Options

Rated Input Voltage	Rated Output Current (Amps)	Nominal HP <sup>1</sup>	NEMA 3R Configured Matrix (With EMC filter) <sup>2</sup>	Power Options				
				Circuit Breaker (100 kAIC)	Output Reactor	EMC Filter	Surge Suppressor	Space Heater
			Z1E3. . . . xx	M	K	N <sup>2</sup>	7	3
208 V 3-Phase	24.2	7.5	D024PN	-	K	Included	7	-
	30.8	10	D030PN					
	46.2	15	D046PN					
	59.4	20	D059PN					
	74.8	25	D074PN					
	88	30	D088PN					
	114	40	D114PN					
	143	50	D143PN					
	169	60	D169PN					
	211	75	D211PN					

- Horsepower rating is based on standard NEMA B, 4-pole motor design as represented in NEC table 430.150 Full-Load Current, Three-Phase Alternating Current Motors at 208 volts.
- Includes an internal EMC filter.

Table 141: 480 V Models and Power Options

Rated Input Voltage	Rated Output Current (Amps)	Nominal HP <sup>1</sup>	NEMA 3R Configured Matrix (With EMC filter) <sup>2</sup>	Power Options				
				Circuit Breaker (100 kAIC)	Output Reactor	EMC Filter	Surge Suppressor	Space Heater
			Z1E3. . . . xx	M	K	N <sup>2</sup>	7	3
480 V 3-Phase	11	7.5	B011PN	-		Included		-
	14	10	B014PN					
	21	15	B021PN					
	27	20	B027PN					
	34	25	B034PN					
	40	30	B040PN					
	52	40	B052PN					
	65	50	B065PN					
	77	60	B077PN					
	96	75	B096PN					
	124	100	B124PN					
	156	125	B156PN					
	180	150	B180PN					
	240	200	B240PN					
	302	250	B302PN					
361	300	B361PN						
414	350	B414PN						

1. Horsepower rating is based on standard NEMA B, 4-pole motor design as represented in NEC table 430.150 Full-Load Current, Three-Phase Alternating Current Motors at 480 volts.  
 2. Includes an internal EMC filter.

## Dimensions and Data (Z1E3)

Refer to the product page on the Yaskawa website for dimension, weight, and schematic diagram data depending on drive model and installed options.

Use document [PD.Z1000.05](#) for 208 V models.

Use document [PD.Z1000.06](#) for 480 V models



# Terms and Conditions

## YASKAWA AMERICA, INC. ("YAI"), DRIVES & MOTION TERMS AND CONDITIONS

### 1. GENERAL:

(a) All sales of products or services by Yaskawa America, Inc., Drives & Motion Division (hereinafter "D&M"), is governed exclusively by these Terms and Conditions of Sale ("Terms"), which supersede all inconsistent or additional terms on Buyer's purchase order or any other document. These Terms constitute the final, complete and exclusive agreement between the parties as to the subject matter hereof. These Terms may be amended only in writing signed by an authorized representative of D&M.

(b) Orders must be submitted in the form of a written purchase order or letter from Buyer, setting forth all information necessary for D&M to fill the Order, if accepted. All proposals, quotations or similar communications from D&M are considered invitations to submit an Order. A binding sales contract will result only when D&M accepts Buyer's Order, at D&M's office in Waukegan, Illinois or such other place as designated by D&M.

### 2. PRICES:

(a) D&M's quoted prices are firm for thirty (30) days from the date of D&M's written proposal. Thereafter, the applicable prices are those in effect at the time Buyer's Order is placed with D&M. D&M will notify Buyer of any price changes for incorporation into a revised Order prior to acceptance by D&M. Pricing based on volume discounts is subject to adjustment by D&M if actual shipping volumes do not meet minimum volume requirements of agreement. Clerical errors in any element of a proposal, purchase order, invoice or contract are subject to correction by D&M.

### 3. TERMS OF PAYMENT:

(a) All payments are due within thirty (30) days from date of D&M's invoice. Payment shall be made at the agreed time, to the place specified, and in the currency indicated on D&M's invoice. D&M reserves the right to require payment in advance, or satisfactory security, for any shipment or sale. D&M reserves the right to seek any other remedy available at law or equity and Buyer shall be liable for all expenses, including attorneys' fees, relating to the collection of past due amounts. Buyer's default constitutes a waiver of Buyer's right to demand D&M's performance under the contract.

(b) When an amount becomes past due according to its payment terms, Buyer shall pay interest on the balance due, at the greater of 1.50% per month (18% per annum) or the maximum permitted by law, until paid in full.

(c) If delivery and/or payment in installments is accepted by D&M, Buyer's failure to pay any installment when due shall give D&M the right to suspend work or delivery until such payment is made. In the event that any such default by Buyer continues for more than fifteen (15) days, D&M may then cancel the contract by written notice to Buyer.

(d) All duties, tariffs, fees, costs and other charges connected with shipment, insurance, exportation and importation of the products are the responsibility of Buyer, and, if paid by D&M, such expenses may be recovered by D&M from Buyer, and Buyer shall indemnify D&M against claims for the same. Buyer is responsible for all taxes applicable or related to this transaction, including all sales, use and excise taxes.

### 4. SECURITY INTEREST:

To secure any indebtedness due and owing from Buyer from time to time, Buyer hereby grants to D&M, and D&M hereby reserves, a continuing purchase money security interest in all Yaskawa-brand and other products heretofore or hereafter sold and delivered to Buyer by D&M, and all related parts, components and accessories therefor, and all proceeds arising from the sale or other disposition of the foregoing, including, but not limited to, cash, accounts, contract rights, accounts receivable, instruments and chattel paper. Buyer shall at no time grant any security interest that conflicts with that granted to D&M herein. Buyer shall cooperate with D&M, and hereby appoints D&M as its attorney-in-fact, to execute and file, on Buyer's behalf, any documents necessary to evidence and perfect D&M's security interest. D&M reserves all rights and remedies available to it under the Uniform Commercial Code and other applicable law in the event of Buyer's default.

### 5. SHIPMENT, FORCE MAJEURE, AND ERROR:

(a) Shipment/delivery dates are approximations only. D&M shall not be liable to pay any penalty or damages, including consequential damages, for any delay in shipment.

(b) All shipments are F.O.B. D&M's (or its suppliers') manufacturing plant or warehouse. D&M will, at Buyer's expense, arrange for the transportation of the products from the manufacturing plant or warehouse designated by D&M. All products shall be packaged for domestic shipment in accordance with D&M's standard specifications. If special packaging is required, it must be clearly requested on Buyer's Order. The price for any special packaging shall be billed to Buyer. Buyer is responsible to timely procure all necessary export and import licenses and all permits required for the consummation of the transaction and to obtain insurance coverage on all shipments of products supplied by D&M. Risk of loss and/or damage to the products shall pass to Buyer upon delivery thereof to Buyer or its representative, or to a carrier for shipment to Buyer or its designated customer, as the case may be, at the FOB point.

(c) D&M shall not be liable for any damages, including consequential damages, caused by delays or non-performance resulting from or related to force majeure or other causes beyond D&M's reasonable control, including, but not limited to, war, blockade, civil disturbances, strikes and lockouts, labor shortages, fire and other casualties, acts of nature, accidents and governmental acts (including regulations concerning export and import licensing and currency exchange). In case of non-delivery, D&M's obligation shall be limited to the refund of any advance payment received from Buyer.

(d) All claims for loss of or damage to products, whether concealed or obvious, must be made, in writing, to the carrier and to D&M by Buyer as soon as possible after receipt of shipment, and in no case beyond 30 days of shipment, or such claims shall be deemed waived. D&M will render reasonable assistance in providing information necessary for Buyer to process such damage claims with the carrier or any insurance company.

(e) Buyer agrees to accept delivery within fifteen (15) days following the anticipated date of delivery. If Buyer refuses to take delivery within the fifteen (15) day period, D&M reserves the right to charge Buyer for storage charges plus interest.

### 6. RETURNS/CANCELLATION CHARGES:

Buyer shall not return products to D&M without the written consent of, and upon terms agreed to, by D&M. If Buyer refuses to accept delivery, or improperly revokes

acceptance of product, Buyer shall be responsible for D&M's cancellation charges and expenses. Before any returns, a Return Merchandise Authorization ("R.M.A.") number must be obtained from D&M. Products returned without an R.M.A. number clearly marked on the outside of the shipping carton will be refused. Except for approved warranty returns, D&M will only accept for return and credit new, unused, undamaged, current stock items, in the original packaging. Buyer shall be responsible for all freight charges, import/export charges, duties, tariffs, taxes, insurance and risk of loss/damage regarding return shipment to D&M.

#### 7. DRAWINGS/MEASUREMENTS:

All ratings, drawings, tables, graphs and the like submitted by D&M or set forth in written materials or on the company's website are approximations only. Weights, measurements, capacities and all other particulars of products or services offered by D&M are approximations only. D&M is not responsible for such approximations, including, in particular, based on data supplied by Buyer.

#### 8. LIMITED WARRANTY:

(a) At the time of shipment, new and unused product shall be free from defects in materials and workmanship. D&M warrants that for a period of one (1) year from the date the product is first used by Buyer, or 18 months from the date of shipment, whichever occurs first, if any product or part is found by D&M to be defective, D&M will, at its sole discretion and as Buyer's exclusive remedy, either repair, replace or return the purchase price paid to D&M; provided that the subject product is used under normal conditions for which it was designed and installed, operated and maintained in accordance with D&M's instructions and in accordance with generally accepted industrial practices. Products repaired or replaced during the warranty period shall be covered by the foregoing warranty for the remainder of the original warranty period or ninety (90) days from date of the repair or shipment of the replacement, whichever is longer. D&M warrants, for a period of ninety (90) days, that services shall be performed in a workman like manner. Buyer's sole remedy for a breach of this service warranty is limited to further service or a refund or credit of amounts paid by Buyer, at Seller's option. (b) D&M's warranty obligation shall be conditioned upon receipt by D&M of written notice of any alleged defects within sixty (60) days after discovery. D&M will not be responsible for unauthorized repairs to any products, even if defective. D&M shall not be responsible for any products which have been altered, abused, misused, or improperly installed or repaired, or for any loss, damage, defect, claim or nonperformance resulting from or attributable to Buyer's specifications. D&M does not guarantee production rates or the quality of goods made using D&M's products or services, nor shall any longer warranty periods apply, except as agreed in writing signed by an authorized D&M representative. (c) Where Buyer orders non-stock products or parts manufactured by a third-party, D&M will, to the extent permitted, pass through to Buyer any warranty of the manufacturer. As to such items, Buyer's sole remedy for breach of warranty shall be the remedy offered by and available from the manufacturer, if any. (d) D&M'S WARRANTY HEREIN IS IN LIEU OF AND EXCLUDES ALL OTHER WARRANTIES OF D&M AND ANY PARENT OR AFFILIATED COMPANIES OF D&M. D&M DISCLAIMS ALL OTHER WARRANTIES, WHETHER EXPRESS, IMPLIED OR STATUTORY, INCLUDING, BUT NOT LIMITED TO, ANY IMPLIED WARRANTIES OF MERCHANTABILITY AND/OR FITNESS FOR A PARTICULAR PURPOSE OR USE. (e) UNDER NO CIRCUMSTANCES SHALL D&M, OR ANY PARENT OR AFFILIATED COMPANY OF D&M, BE LIABLE TO BUYER OR ANY ENTITY FOR ANY SPECIAL, INDIRECT OR CONSEQUENTIAL DAMAGES, WHETHER ARISING FROM BREACH OF CONTRACT, TORT, NEGLIGENCE, MISREPRESENTATION, STRICT LIABILITY OR OTHERWISE, INCLUDING FOR LOST PROFITS, IMPAIRMENT OF GOODS, WORK STOPPAGE OR OTHERWISE, IN ANY WAY ARISING OUT OF OR RELATED TO PRODUCTS OR SERVICES SUPPLIED BY D&M OR ANY TRANSACTION TO WHICH THESE STANDARD TERMS APPLY. THE MAXIMUM LIABILITY OF D&M, INCLUDING, BUT NOT LIMITED TO, WITH RESPECT TO THE DESIGN, MANUFACTURE, SALE, DELIVERY, RESALE, INSPECTION, ASSEMBLY, INSTALLATION, TESTING, REPAIR, REPLACEMENT, MAINTENANCE OR USE OF ANY PRODUCT OR THE PERFORMANCE OF ANY SERVICE, SHALL NOT EXCEED THE PURCHASE PRICE PAID TO D&M.

#### 9. INFRINGEMENT:

The liability of D&M, any parent or affiliated company for patent infringement is limited to D&M's defense of proceeding brought against Buyer based on a claim that products, when employed in the manner intended by D&M, constitutes an infringement of any U.S. patent. If Buyer's use of the products in the manner intended by D&M is finally enjoined in such action, D&M shall, at its option, procure for Buyer the right to continue using the products, replace the same with non-infringing products, modify the products so that they become non-infringing equivalent products, or refund the purchase price (less allowance for use, damage or obsolescence). D&M makes no warranty against patent infringement resulting from portions of the products made to Buyer's specifications or the use of products in combination with any other goods or in the practice of any process, and if a claim is brought against D&M or any parent or affiliate of D&M, Buyer shall defend, indemnify and hold D&M (and its parent/affiliates) harmless from and against any and all claims, losses or damages arising therefrom.

#### 10. GOVERNING LAW, FORUM AND JURY WAIVER:

These Terms and the relationship of the parties are governed by the internal laws of the State of Illinois, U.S.A., without regard to its choice of law rules. For all claims or disputes arising out of or relating to the sale of products or services by D&M and/or the relationship of the parties, Buyer shall file any and all lawsuits or claims exclusively in the state or federal courts located in Cook County, Illinois. Buyer hereby submits to the personal jurisdiction of said courts and waives any claim of improper or inconvenient venue. To the fullest extent permitted by law, Buyer hereby agrees to waive the right to trial by jury for all claims or disputes arising out of or relating to the sale of products or services by D&M and/or the relationship of Buyer and D&M. The parties agree that U.N. Convention of Contracts for the international Sale of Goods shall not apply to their relationship or the sale of products by D&M.

#### 11. EXPORT CONTROL:

Buyer acknowledges that the products and related software and technology may be subject to export controls of the U.S. Government, including the Export Administration Regulations of the U.S. Department of Commerce. Buyer shall comply with all applicable laws, regulations, treaties and agreements regarding the use, import, export or re-export of the products and shall be solely responsible for obtaining all required licenses or approvals. The products are not intended for use in any nuclear, chemical or weapons production or environmental damage or for export, re-export, or distribution to any restricted or embargoed country or to a person or entity whose privilege to participate in exports has been denied or restricted by the U.S. Government. Buyer shall indemnify, hold harmless and defend D&M, its parent and affiliated companies from any violation of this section by Buyer or its employees, consultants, agents and customers.

#### 12. MISCELLANEOUS:

- (a) Failure on the part of D&M to enforce any of its rights derived from these Terms shall never be construed as a waiver of any of D&M's rights.
- (b) The invalidity of one or more of the clauses herein shall not affect the validity of the other clauses, which for this purpose are considered severable.
- (c) Any use by Buyer of any a YAI trademark must be approved by YAI in writing.
- (d) Buyer may not delegate its performance or assign its rights under these Terms except upon the express written consent of D&M. In any case, these Terms shall be binding upon the successors and legal representatives of Buyer.



YASKAWA.COM



Yaskawa is the leading global manufacturer of low and medium voltage variable frequency drives, servo systems, machine controllers and industrial robots. Our standard products, as well as tailor-made solutions, are well known and have a high reputation for outstanding quality and reliability.

# YASKAWA

**YASKAWA AMERICA, INC.** | Drives & Motion Division

1-800-YASKAWA | Email: [info@yaskawa.com](mailto:info@yaskawa.com) | [yaskawa.com](http://yaskawa.com)

Document No. CA.HV600.01 Rev B4 | 10/20/2022 | © 2021–2022 Yaskawa America, Inc.